

Profilers **Samplers** Flotation



[mclanelabs.com](http://mclanelabs.com)

# Water Transfer System

## User Manual



2018 McLane Research Laboratories, Inc., Rev.18.G.09

Tel: +1 (508) 495-4000  
mclane@mclanelabs.com

Skype: mclane\_research  
www.mclanelabs.com

# WTS-LV User Manual Table of Contents

<b>Chapter 1 Introduction .....</b>	<b>1-1</b>
User Key .....	1-1
Customer Resources .....	1-1
Technical Support .....	1-2
Instrument Training .....	1-2
<b>Chapter 2 System Description .....</b>	<b>2-1</b>
System Overview .....	2-1
WTS-LV Models .....	2-2
System Components .....	2-2
Frame .....	2-2
Cable Clamps .....	2-3
Clamp Inserts .....	2-3
Controller Housing .....	2-4
End Caps and O-Rings .....	2-5
End Cap Bulkhead Connectors .....	2-6
Pressure Relief Valve .....	2-7
Trigger Feature .....	2-7
Trigger Option Wiring Diagram .....	2-8
Pump .....	2-9
Pump Speed Algorithm .....	2-9
Filter Holders .....	2-10
Filter Material .....	2-12
Flow Meter .....	2-14
WTS-LV Toolkit .....	2-15
Serial Number .....	2-15
Electronics .....	2-16
Communications Bulkhead Connector Styles .....	2-17
Main Battery .....	2-18
Backup Battery .....	2-19
<b>Chapter 3 WTS-LV Deployment Description .....</b>	<b>3-1</b>
Deployment Overview .....	3-1
Procedure Parameters .....	3-1
Sample Volume and Flow Rates .....	3-1
<b>Chapter 4 Getting Started .....</b>	<b>4-1</b>
Connecting the Sampler to a Computer .....	4-1
Connecting a Computer .....	4-1
Troubleshooting the USB Adaptor .....	4-2
Installing and Configuring McLaneTerm .....	4-2
Powering up the Sampler .....	4-3
Opening the Controller Housing .....	4-3
Connecting the Batteries .....	4-5
Establishing Communication with the Firmware .....	4-6
Waking the Sampler from Low Power Sleep Mode .....	4-7

<b>Chapter 5 User Interface.....</b>	<b>5-1</b>
Main Menu.....	5-1
<1> Set Time .....	5-2
<2> Diagnostics.....	5-3
Battery Warnings.....	5-4
<3> Manual Operations.....	5-4
<4> Sleep.....	5-5
<5> Deploy System .....	5-5
<6> Offload Data.....	5-5
<7> Contacting McLane.....	5-6
Configuration Menu.....	5-6
Configuring the System .....	5-7
<b>Chapter 6 Deployment Preparation.....</b>	<b>6-1</b>
Closing and Sealing the Controller Housing .....	6-1
Checking the Zinc Anodes.....	6-1
Priming the WTS-LV .....	6-2
Installing Filters and Priming - Radial Intake Filter Holders .....	6-3
Correct Filter Plate Assembly.....	6-8
Installing Filters and Priming - Vertical Intake Filter Holders.....	6-9
Correct Filter Plate Assembly.....	6-14
Estimating Instrument Current Consumption.....	6-15
Programming Deployment Parameters.....	6-16
Flow Rates .....	6-17
Start Options .....	6-17
Sample Pump Data Period .....	6-17
Trigger Start Delay .....	6-18
Starting the Deployment.....	6-20
Final steps before Deployment.....	6-21
Steps for Connecting the WTS-LV to the wire.....	6-21
<b>Chapter 7 Deployment Recovery and System Maintenance.....</b>	<b>7-1</b>
Recovery Procedure.....	7-1
Removing the Filter .....	7-1
Offloading Deployment Data .....	7-2
Offload menu options: .....	7-2
Option <4> EEPROM Data Backup Cache.....	7-5
System Maintenance.....	7-6
Flushing the WTS-LV Pump Head.....	7-6
Cleaning and Inspecting the Filter Holder.....	7-7
Rinsing the System .....	7-7
Inspecting the O-Rings .....	7-7
Storage .....	7-8
O-Ring Maintenance.....	7-9
Cleaning and Inspecting the Controller Housing.....	7-10

<b>Appendix A WTS-LV Models.....</b>	<b>A-1</b>
<b>Section A.1 WTS-LV Dual Filter Model.....</b>	<b>A-3</b>
<b>Section A.1.1 Specifications.....</b>	<b>A-4</b>
WTS-LV Dual Filter Model Dimensions .....	A-4
Filter Porosity .....	A-4
<b>Section A.1.2 WTS-LVDF Operations.....</b>	<b>A-6</b>
Removing Filter Holders .....	A-7
Installing Filter Holders.....	A-8
<b>Section A.1.3 WTS-LVDF Deployment Preparation.....</b>	<b>A-9</b>
Installing the Optional Debubbler .....	A-9
Connecting the Battery .....	A-10
Priming the WTS-LV-DF .....	A-13
Reading and Recording Flow Meters .....	A-15
<b>Section A.2 WTS-LV Upright Model.....</b>	<b>A-16</b>
WTS-LV Upright Model Dimensions .....	A-17
Connecting the Battery .....	A-17
Trigger Start.....	A-19
Deploy.....	A-20
<b>Section A.3 WTS-LV Bore Hole Model .....</b>	<b>A-22</b>
Installing the Batteries .....	A-24
<b>Appendix B Optional Filter Holders.....</b>	<b>B-1</b>
WTS-LV with Optional 3-Tier Filter Holders.....	B-2
WTS-LV with Optional Cartridge Filter Holder .....	B-3
<b>Appendix C Pump Head Sizing and Filter Types.....</b>	<b>C-1</b>
Available WTS-LV Pump Heads .....	C-1
Filter Types and Recommended Pump Heads .....	C-1
<b>Appendix D Using the 30L/Min Pump.....</b>	<b>D-1</b>
Deployment Programming Settings.....	D-3
Battery Endurance Example Calculation.....	D-5
Battery Estimate – A72-1000 Battery.....	D-5
<b>Appendix E Training Videos .....</b>	<b>E-1</b>



## WTS-LV User Manual List of Figures

Figure 2-1: Standard WTS-LV Full View .....	2-1
Figure 2-2: Cable Clamp Inserts .....	2-3
Figure 2-3: Bottom Clamp .....	2-4
Figure 2-4: Top Clamp .....	2-4
Figure 2-5: Controller Housing .....	2-4
Figure 2-6: Controller Housing Top End Cap, with O-Ring Seals .....	2-5
Figure 2-7: Controller Housing End Cap Bulkhead Connectors .....	2-6
Figure 2-7: Trigger Plug .....	2-7
Figure 2-8: WTS-LV Trigger Wiring Diagram .....	2-8
Figure 2-9: WTS-LV Pump Assembly .....	2-9
Figure 2-10: 142mm Radial Intake Filter Holder Schematic .....	2-10
Figure 2-11: 142mm Vertical Intake Filter Holder Schematic .....	2-11
Figure 2-12: WTS-LV Filter Holders .....	2-11
Figure 2-13: Filter Types and Recommended Pump Heads .....	2-13
Figure 2-14: Flow Meter .....	2-14
Figure 2-15: WTS-LV Toolkit .....	2-15
Figure 2-16: USB Communications .....	2-16
Figure 2-17: Communications Cable Connector Style .....	2-17
Figure 2-18: Main Battery Holder- Standard WTS-LV .....	2-18
Figure 2-19: Backup Battery 9V and AAA Styles (Older Model WTS-LV systems) ..	2-19
Figure 4-1: Communications Cable .....	4-1
Figure 4-2: Releasing Pressure Relief Valve (Flat Style) .....	4-3
Figure 4-3: Releasing Pressure Relief Valve (Style with Release Tool) .....	4-4
Figure 4-4: Separating the Housing and End Cap .....	4-4
Figure 4-5: Connecting the Battery .....	4-5
Figure 4-6: Connecting the COM Cable .....	4-6
Figure 4-7: Main Menu .....	4-7
Figure 5-1: WTS-LV Main Menu .....	5-1
Figure 5-2: Set Time .....	5-2
Figure 5-3: Diagnostics .....	5-3
Figure 5-4: Manual Operation Menu – Configured for 8L/min Pump Head .....	5-4
Figure 5-5: Suspend/Sleep Mode .....	5-5
Figure 5-6: McLane Contact Information .....	5-6
Figure 5-7: Configuration Menu .....	5-6
Figure 5-8: Configuration for Rechargeable Batteries .....	5-7

Figure 6-1: Radial Intake Filter Holder .....	6-2
Figure 6-2: Vertical Intake Filter Holder .....	6-2
Figure 6-3: Tubing and Quick Disconnect .....	6-3
Figure 6-4: Wetting the Bottom Filter Holder Plate .....	6-4
Figure 6-5: Placing the Filter on the Bottom Filter Holder Plate .....	6-4
Figure 6-6: Soaking the Installed Filter .....	6-5
Figure 6-7: Seating the Pre-Filter Plate Rubber Gasket .....	6-6
Figure 6-8: Placing the Pre-Filter Plate on the Filter Holder.....	6-6
Figure 6-9: Fill the Pre-Filter Plate until Water Pools.....	6-7
Figure 6-10: Install Filter and Top Section.....	6-7
Figure 6-11: Tighten Nuts and Fill Assembly with Neutral Water .....	6-8
Figure 6-12: Correctly Closed Filter Holder.....	6-8
Figure 6-13: Incorrectly Closed Filter Holder .....	6-8
Figure 6-14: Vertical Intake Filter Holder .....	6-9
Figure 6-15: Flood the Filter Holder Bottom Plate.....	6-10
Figure 6-16: Placing the Filter onto the Filter Holder Plate .....	6-10
Figure 6-17: Installing the Pre-Filter Plate .....	6-11
Figure 6-18: Secure Seal in Plate Groove.....	6-11
Figure 6-19: Installing the Pre Filter.....	6-12
Figure 6-20: Installing the Optional Gasket to Seal the Pre Filter.....	6-12
Figure 6-21: Install Filter Top and Tighten Wing Nuts.....	6-13
Figure 6-22: Fill the Filter Holder Assembly with Neutral Water .....	6-13
Figure 6-23: Correctly Closed Filter Holder .....	6-14
Figure 6-24: Incorrectly Closed Filter Holder .....	6-14
Figure 6-25: Deployment Parameters .....	6-16
Figure 6-26: Setting Trigger Countdown Delay .....	6-18
Figure 6-27: Trigger Plug .....	6-18
Figure 6-28: Proceed with Deployment, Trigger Activated .....	6-19
Figure 6-29: Bottom Clamp      Figure 6-30: Top Clamp .....	6-21
Figure 7-1: Offload/Display Data File Menu .....	7-2
Figure 7-2: Offload/Display Data File – Display All (1 of 2) .....	7-3
Figure 7-3: Offload/Display Data File – Display All (2 of 2) .....	7-4
Figure 7-4: EEPROM Data Backup Cache.....	7-5
Figure 7-5: Controller Housing Top End Cap with O-Ring Seals.....	7-9



Figure A.1-1: WTS-LV Dual Filter Model.....	A-3
Figure A.1.1-1: WTSLV-DF Filter Holder Cross Section.....	A-4
Figure A.1.1-2: WTSLV-DF Fluidic Diagram .....	A-5
Figure A.1.2-1: Valve Closed .....	A-6
Figure A.1.2-2: Valve Open .....	A-6
Figure A.1.2-3: Remove Nuts and Release Quick Disconnect.....	A-7
Figure A.1.2-4: Lifting Filter Holder off of Plate.....	A-7
Figure A.1.2-5: Securing Filter Holder to Quick Disconnect.....	A-8
Figure A.1.2-6: Flow Valve Positioned for Dual Filtering.....	A-8
Figure A.1.3-1: Debubbler Plug .....	A-9
Figure A.1.3-2: Screw Debubbler into Manifold.....	A-9
Figure A.1.3-3: WTS-LVDF Controller with A72-1000 Battery Pack .....	A-10
Figure A.1.3-4: Removing Battery Housing End Plate .....	A-11
Figure A.1.3-5: Align Battery to Fit Connector Through Hole in Top Plate.....	A-11
Figure A.1.3-6: Feeding Battery Connection Wires and Connecting Battery .....	A-12
Figure A.1.3-7: Priming Tubing and Quick Disconnect.....	A-13
Figure A.1.3-8: Run Pump Forward .....	A-13
Figure A.1.3-9:Setting the Flow Valve.....	A-14
Figure A.1.3-10: Filling Filter Holder Top with Water.....	A-14
Figure A.1.3-11:Mechanical Flow Meters.....	A-15
Figure A.2-1: WTS-LV Upright Model.....	A-16
Figure A.2-2: WTS-LVUP Controller with A72-1000 Battery Pack .....	A-17
Figure A.2-3: Removing Battery Housing End Plate .....	A-18
Figure A.2-4: Align Battery to Fit Connector Through Hole in Top Plate.....	A-18
Figure A.2-5: Correctly Feeding Battery Connection Wires and Connecting Battery	A-19
Figure A.2-6: System Status .....	A-20
Figure A.2-7: Deploy System – Trigger Installed .....	A-21
Figure A.3-1: Bore Hole WTS-LV .....	A-22
Figure A.3-2: Bore Hole WTS-LV Schematic .....	A-23
Figure A.3-3: WTS-LV Frame Guards, U-Bolts and Orientation Arrows .....	A-24
Figure A.3-4: 7/16" Box Wrench, Adjustable Wrench.....	A-24
Figure A.3-5: Moving Exhaust Tubing.....	A-24
Figure A.3-6: Place on a Stable Surface .....	A-25
Figure A.3-7: Removing Connector .....	A-25
Figure A.3-8: Loosening Frame Guard.....	A-25
Figure A.3-9: Removing Leg Bolt.....	A-26
Figure A.3-10: Loosening U-Bolt Clamp.....	A-26
Figure A.3-11: Removing U-Bolt.....	A-26
Figure A.3-12: Removing Controller Housing.....	A-26

Figure A.3-13: Main and Backup Batteries .....	A-28
Figure A.3-14: Returning Controller to Frame .....	A-28
Figure A.3-15: Aligning Arrows, Reattaching Connector .....	A-28
Figure B-1: Filter Holder Specifications Chart .....	B-1
Figure B-2: WTS-LV 3-Tier Filter Holder .....	B-2
Figure B-3: WTS-LV with Cartridge Filter Holders .....	B-3
Figure B-4: Exhaust Port .....	B-4
Figure D-1: WTS-LV Upright with 30L/min Pump Head .....	D-1
Figure D-2: WTS-LV Configuration Settings .....	D-3
Figure D-3: WTS-LV Deployment Settings .....	D-4

# Chapter 1

## Introduction

This user manual is designed to provide support for the WTS-LV single sample instrument, from the first steps of powering on and communicating with the instrument, to the final steps of recovering data from a recently deployed system, and storing the instrument. Read this manual and keep a copy as a reference if you plan on using a WTS-LV. McLane user manuals are updated frequently and the latest version can always be downloaded from our website.

### User Key

This User Manual contains the following symbols that call attention to information:



**Note**

This symbol indicates information and tips that are helpful for operating the instrument.

---



**Important**

This symbol indicates information that could affect key product operations.

---



**Caution**

This symbol indicates information that must be followed to prevent instrument damage or user injury.

### Customer Resources

McLane Research Laboratories is on the Web at <http://www.mclanelabs.com> or via email at [mclane@mclanelabs.com](mailto:mclane@mclanelabs.com). The [WTS-LV pages](#) on the McLane website contain links to documentation including Technical Bulletins, and papers that describe the development and use of the WTS-LV.

## Technical Support

When contacting McLane for technical support, please provide the following:

- Firmware version and instrument serial number. Serial number is printed on a label attached to the controller housing, on the Contact McLane screen and also on the Main Menu screen.
- A description of the problem.
- Any relevant capture files (deployment setup, offload data, pumping data stream and so on – capturing all your communications is critical for successful technical support).

## Instrument Training

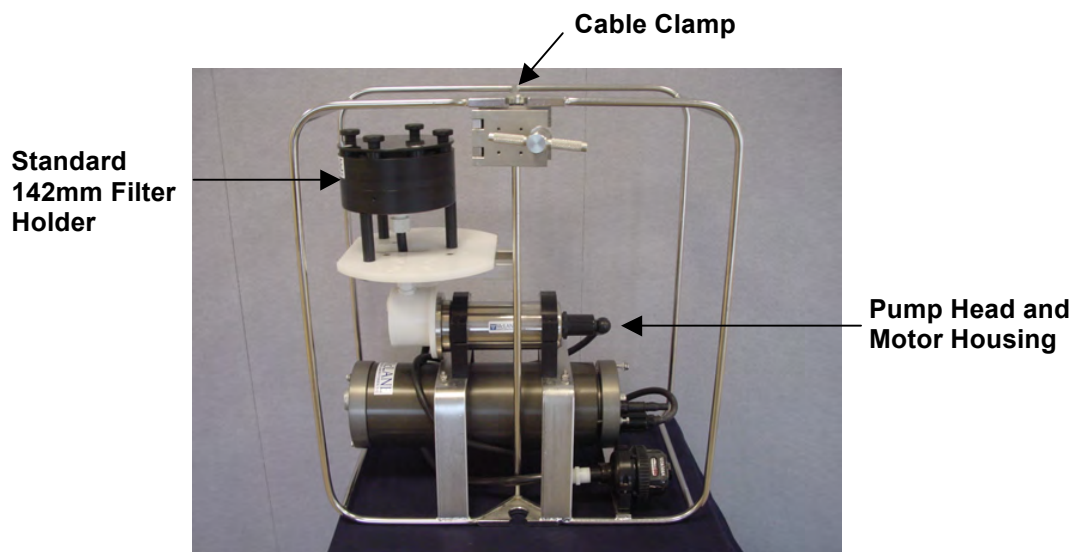
McLane also offers a 1 day WTS-LV course at our facility free of charge with the purchase of a new instrument. Participants conduct trial deployments and work directly with members of the McLane engineering staff. Conducting trial deployments is a beneficial way to learn system operations before actual field investigations. For more [product training](#) information refer to [mclanelabs.com](http://mclanelabs.com).

# Chapter 2

## System Description

### System Overview

The McLane Large Volume Water Transfer System (WTS-LV) is a single-event sampler that collects large volume, in situ particles onto a mesh, GFF or membrane filter. Sampling flow rate is determined by pump head size, filter porosity and filter load. Data recorded during a deployment includes sample volume, initial and minimum flow rates, and pumping period.



*Figure 2-1: Standard WTS-LV Full View*

Available pump heads and resulting flow rates are:

- 4L/min pump head – 1 to 5 liters per minute.
- 8L/min pump head – 4 to 10 liters per minute.
- 30L/min pump head (WTS-LV Upright model) – 12 to 30 liters per minute.

## WTS-LV Models

Several WTS-LV sampler models are available to fit different sampling needs. Examples in this User Manual use the standard WTS-LV model unless otherwise specified.

<b>Model</b>	<b>Description</b>
Standard WTS-LV	Collects samples onto a 142mm membrane filter powered by 24 user replaceable “D” cell batteries.
High Capacity WTS-LV	Collects samples onto a 142mm membrane filter, powered by a 30Ah battery pack with 3 times the capacity of the “D” cells.
Dual Filter WTS-LV	Collects samples onto dual, 142mm membrane filters that perform separately metered parallel filtration. Powered by a 30Ah battery pack with 3 times the capacity of the “D” cells.
Bore Hole WTS-LV	Collects samples onto a 142mm filter, fits through a 30cm hole. Powered by 24 user replaceable “D” cell batteries.

## **System Components**

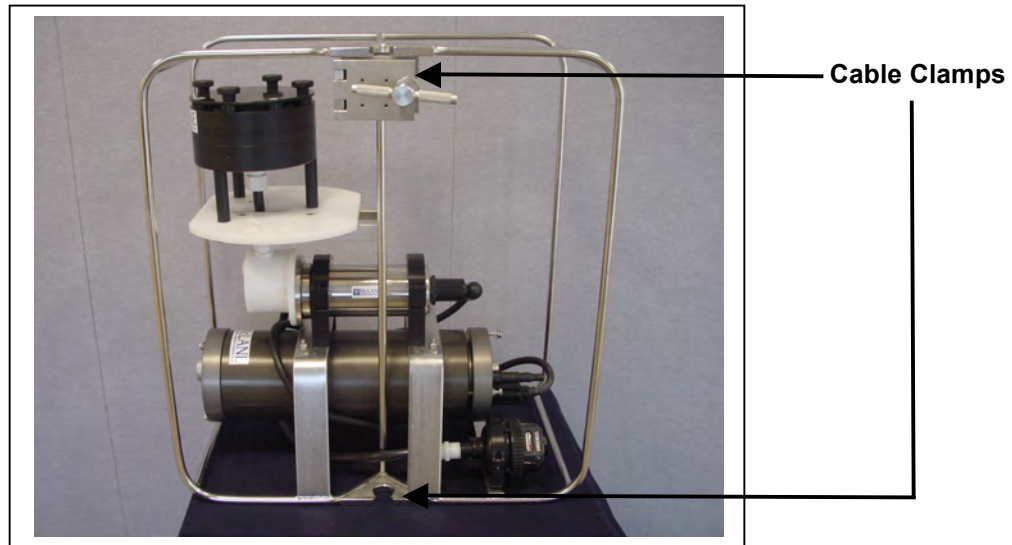
System Components include the frame, cable clamps, controller housing, end caps, and pump. These components are explained in more detail in the section that follows.

### Frame

Components are protected in an electro-polished 316 stainless steel welded frame designed to protect the pump and provide easy access to the filter holder. The frame can be an inline part of a high-tension (up to 2,200 kg) ocean mooring and has built-in top and bottom inserts for cable clamps.

## Cable Clamps

Top and bottom 316 stainless steel wire clamps attach the WTS-LV to a hydro wire without interrupting the cable (an in-line frame option is also available). The clamps fasten to the wire with a threaded bolt and a T-handle nut that compress the stainless steel clamp around the wire. The bottom clamp attaches to the wire first (supporting the full system weight). The top clamp is secured second.



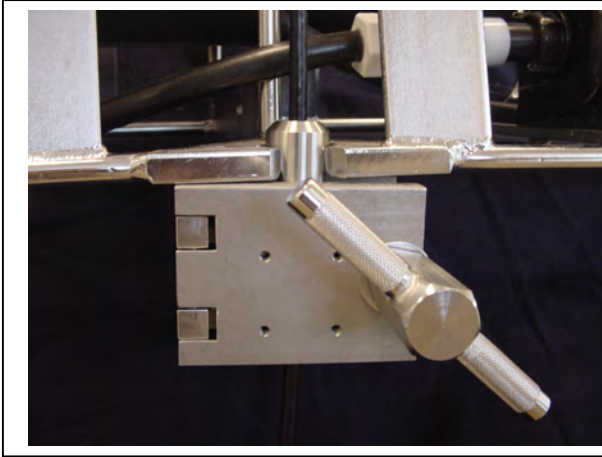
*Figure 2-2: Cable Clamp Inserts*

## Clamp Inserts

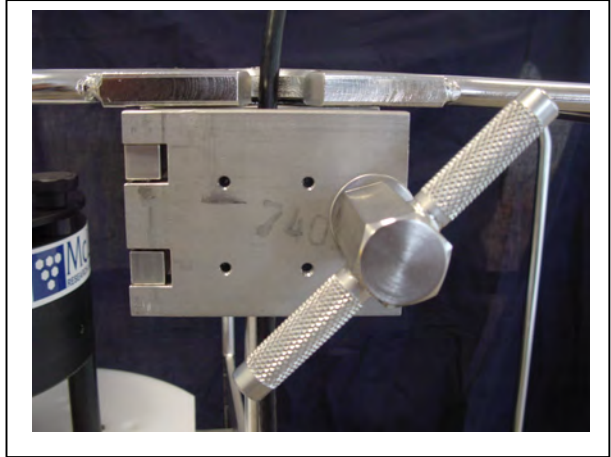
Clamp inserts fit various wire sizes. Wire clamp inserts are designed for the actual outside diameter (OD) of the mooring wire (whether the wire is jacketed or not). For example, 5/16" jacketed wire has a 3/8" OD, and fits a 3/8" clamp insert.

A new WTS-LV includes two sets of wire clamp inserts. Each insert set has one bottom clamp and one top clamp (Figures 2-3 and 2-4). Unless specific sizes are requested, 5/16" and 1/2" inserts are provided with a new WTS-LV. The sizes listed below are available.

Available Clamp Insert Sizes	
1/2"	5/16"
3/8"	7/16"
5/8"	



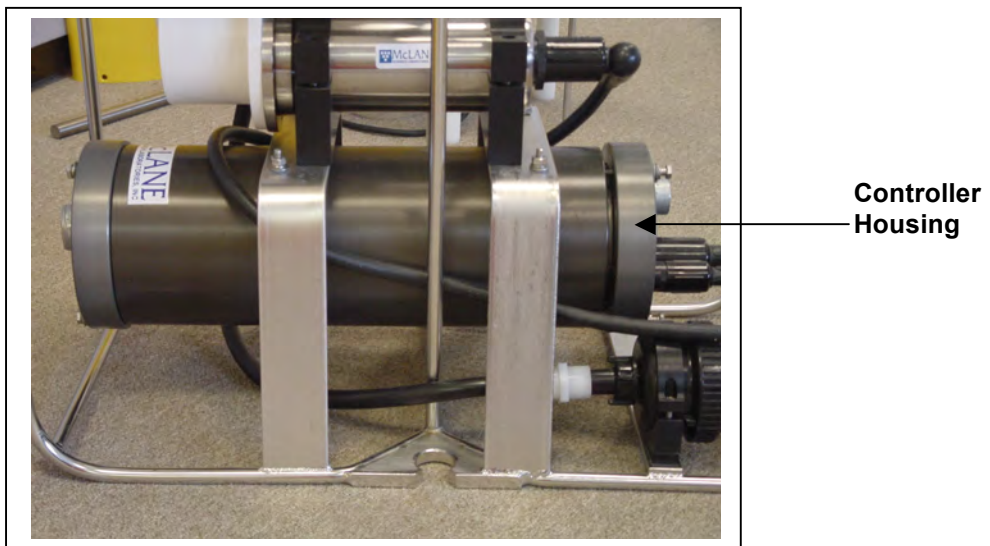
*Figure 2-3: Bottom Clamp*



*Figure 2-4: Top Clamp*

### Controller Housing

The WTS-LV controller housing is a heat-treated aluminum alloy cylinder. The standard WTS-LV controller housing is rated to a depth of 5,500m. The housing holds the battery and electronics. This User Manual contains detailed instructions for opening the controller housing. Follow these instructions and the recommended safety precautions when opening the controller housing.



*Figure 2-5: Controller Housing*

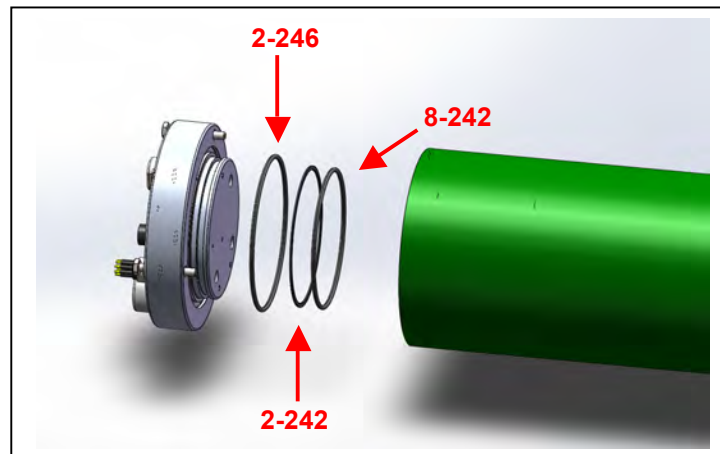


## End Caps and O-Rings

The battery and electronics are fastened to the inside of the controller housing top end cap. Each end cap includes two 70 durometer Buna-N round section o-rings (2-246 and 2-242) and one 90 durometer backup ring (8-242). O-rings and surfaces should be regularly cleaned with isopropyl alcohol. O-rings should be lubricated with provided Parker O-Lube and replaced when necessary. The toolkit has spare O-rings. More o-rings can be purchased from McLane.



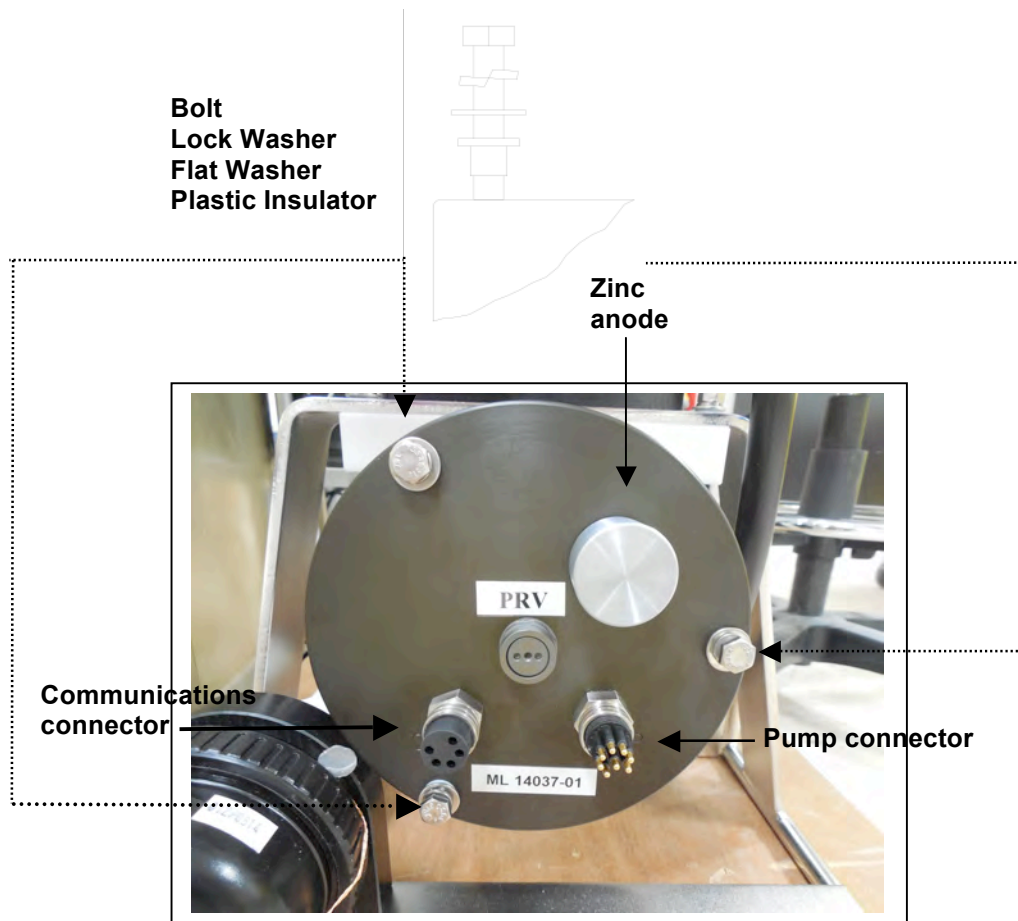
O-ring maintenance and correct placement is critical to keep the controller housing sealed from water intrusion. Incorrect o-ring placement results in cracks or splits that could affect the o-ring seal and cause water damage to the controller. Water damage from incorrectly placed or maintained o-rings could void the sampler warranty.



*Figure 2-6: Controller Housing Top End Cap, with O-Ring Seals*

## End Cap Bulkhead Connectors

The end cap has bulkhead connectors for the Communications connector and Pump (Figure 2-7). The bulkhead assignment (C, P,) is etched into the end cap. A zinc anode is attached to each end on the controller housing end cap to prevent corrosion. Spare zincs are included in the toolkit.



*Figure 2-7: Controller Housing End Cap Bulkhead Connectors*

## Pressure Relief Valve

Attention and care should be taken in maintaining, operating, and opening the pressure housing. As of Summer 2015, McLane includes pressure relief valves (PRV) on all new controller housings.

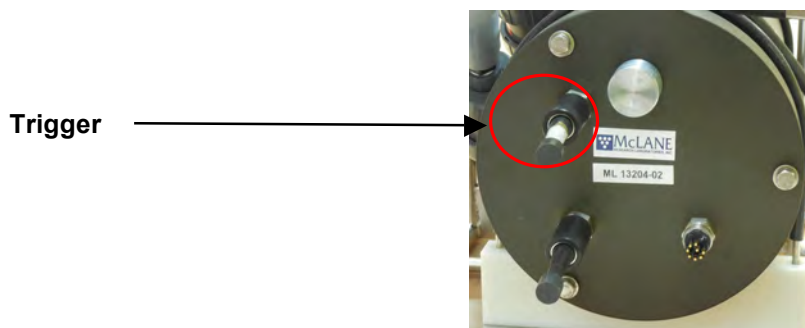


Though unlikely, an unsafe internal controller housing pressure is possible, resulting from the chemical reaction between alkaline electrolyte and anodized aluminum due to battery failure with or without the intrusion of seawater. There can be enough pressure to cause the endcap bolts to fail, especially when one or more are loosened or removed.

Instructions under ‘Powering up the Sampler’ in Chapter 4 of this user manual explain how to use the end cap pressure relief valve.

## Trigger Feature

A trigger start feature allows the user to time synchronize and simultaneously deploy multiple WTS-LV samplers to obtain a profile of large volume water samples. For example, three samplers can be deployed to trigger sample collection at three different depths such as 500m, 1,000m and 1,500m.



*Figure 2-7: Trigger Plug*

# Trigger Option Wiring Diagram

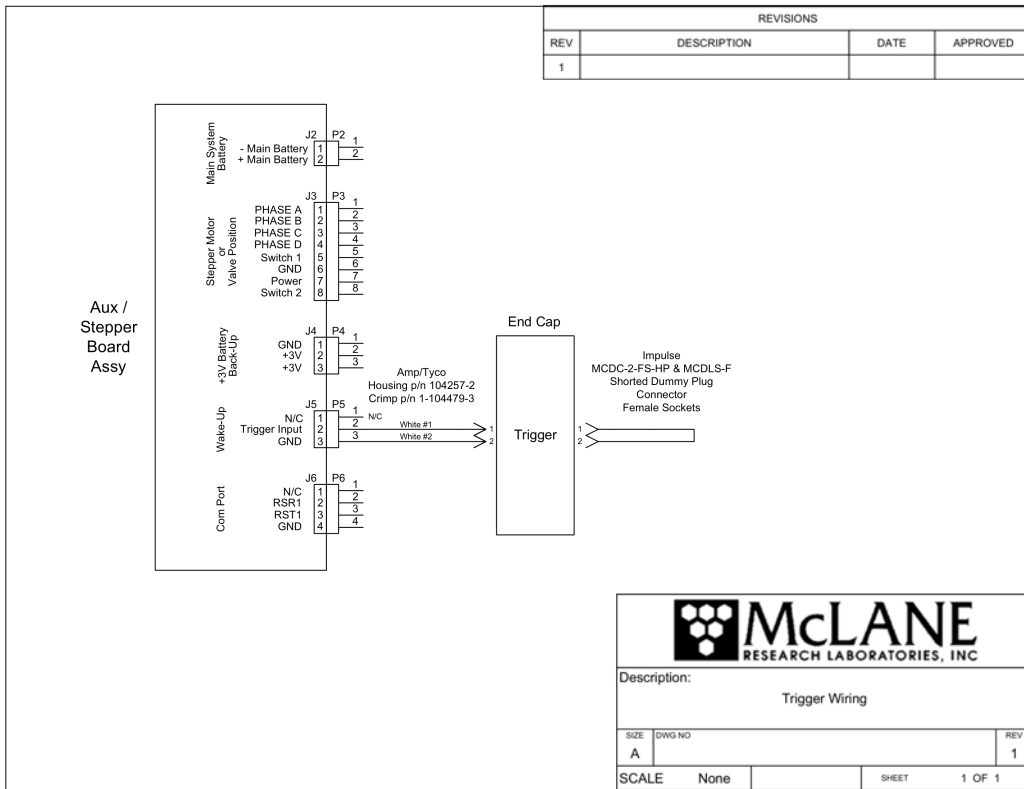
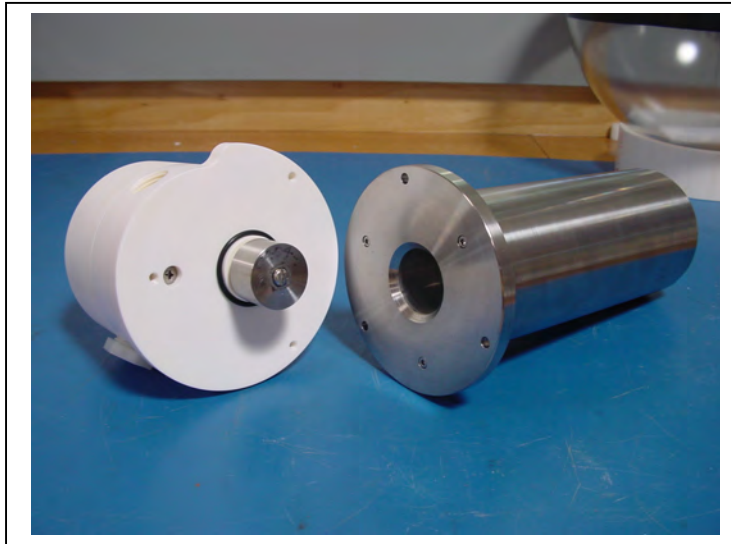


Figure 2-8: WTS-LV Trigger Wiring Diagram

## Pump

The WTS-LV pump assembly is located downstream from the filter holder to prevent sample contamination. A brushless DC 3-phase motor is magnetically coupled to the pump head. Positive displacement pump heads on 4L/min, 8L/min and 30L/min can be used with the WTS-LV.



*Figure 2-9: WTS-LV Pump Assembly*

## Pump Speed Algorithm

A pump speed algorithm in the firmware adjusts flow rate to prevent sample or mesh damage and lower the battery drain. The algorithm adjusts differential pressure as material collects on the filter. If rapid intake clogging occurs, pumping stops to protect the sample.



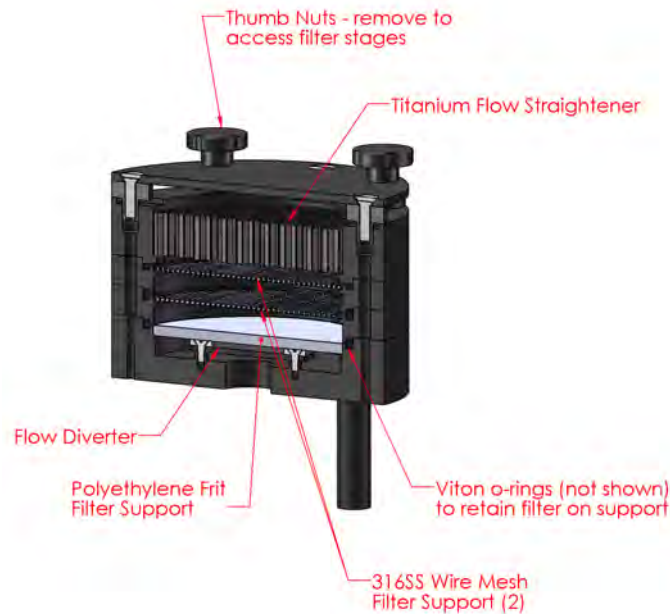
Properly sizing the pump head for the filter type is critical for accurate pump volume calculations. See Appendix C “Pump Head Sizing” in this User Manual for a chart of pump head and filter porosity compatibility and contact McLane with any questions.

## Filter Holders

The standard WTS-LV includes a single 142mm radial intake filter holder. The radial intake filter holder is machined from black acetal stock, with large horizontal intake openings at the top for a low resistance path to the filter.

- Water flow moves through the horizontal intakes and then down through a titanium honeycomb baffle that straightens the flow and suppresses turbulence.
- The water then passes through a 316SS wire pre-filter support.
- The filter holder evenly distributes the sample flow over the entire filter surface. The filter is placed on a support frit approximately 5mm below the base of the baffle.
- Filtered water passes through the frit, down a short length of tubing, and through the pump to the exhaust port.

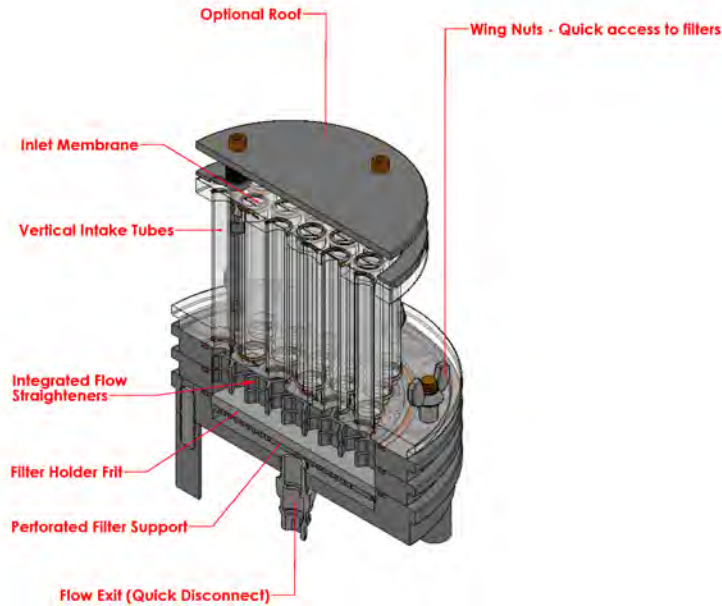
The schematic below illustrates a cross section of the standard 142 mm filter holder.



Flow enters the top of the filter holder around the circumference, passes through the flow straightener and each filter, exiting thru the bottom

*Figure 2-10: 142mm Radial Intake Filter Holder Schematic*

A 142mm vertical intake filter holder can be installed on any WTS-LV model in place of the radial intake filter holder. The vertical intake filter holder has increased internal baffling to mitigate losses of large particles during handling and recovery. Both the vertical and radial intake filter holders can include additional tiers.



*Figure 2-11: 142mm Vertical Intake Filter Holder Schematic*

Other filter holder options are compatible with specific WTS-LV models. Appendix B in this User Manual, “Optional Filter Holders”, lists filter holder and WTS-LV model compatibility.



*Figure 2-12: WTS-LV Filter Holders*

## Filter Material

Filters are supplied by the user. Filter porosity and pump head **must be compatible** for accurate pump volume calculations and pump operation. For example, pumping through a 0.2 $\mu$ m filter should not exceed the recommended maximum flow rate and is recommended only using a 4L/min pump head.

Appendix C in this User Manual, “Pump Head Sizing” lists pump head and filter porosity compatibility. This chart is included on the next page for reference. Contact McLane with any questions about filter and pump head recommendations.





## WTS-LV Filter Types and Recommended Pump Heads

The tables shown next provide a list of available pump heads and recommendations based on compatible filter type and flow rate.

Pump Size	LV04	LV08	LV30
Flow Rate Range (L/min)	1-5	4-10	12-30

\* LV08 is standard on the WTS-LV

Filter Type	Pore Size in $\mu\text{m}$	Max Flow Rate (L/min)	Recommended Pump Heads		
			LV04	LV08	LV30
Polycarbonate and Polyester Membrane (Nucleopore <sup>®</sup> , Millipore <sup>®</sup> )	0.2	3	●		
Polycarbonate and Polyester Membrane (Nucleopore <sup>®</sup> , Millipore <sup>®</sup> )	0.4	4	●		
Polycarbonate and Polyester Membrane (Nucleopore <sup>®</sup> , Millipore <sup>®</sup> )	0.8	8	●	●	
Polycarbonate and Polyester Membrane (Nucleopore <sup>®</sup> , Millipore <sup>®</sup> )	1.0	10	●	●	
Glass Fiber (GF/F <sup>®</sup> , QMA <sup>®</sup> )	0.8	8	●	●	
	1.7	10	●	●	
	5.0	20	●	●	●
Mesh (Nytex <sup>®</sup> )	60.0	30	●	●	●

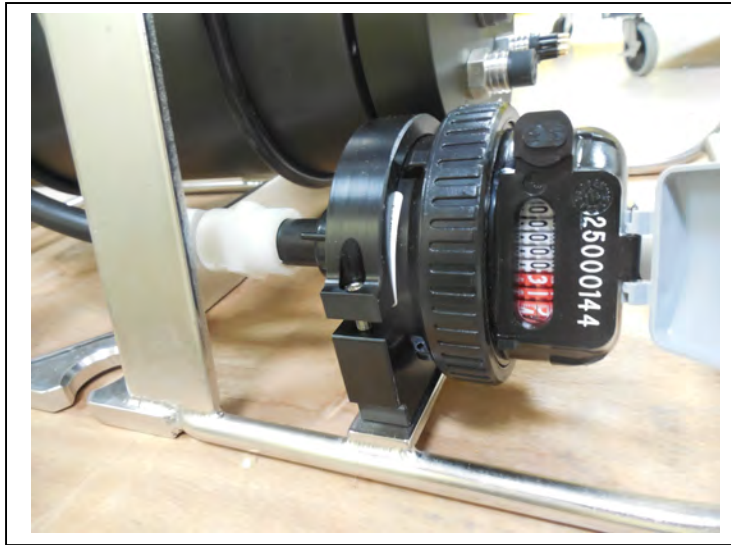
18.F.26

McLane Research Laboratories, Inc. • www.mclanelabs.com • 121 Bernard Saint Jean Drive, East Falmouth, Massachusetts 02536 USA  
Tel: +1 508.495.4000 • Fax: +1 508.495.3333 • Skype: mclane\_research

Figure 2-13: Filter Types and Recommended Pump Heads

## Flow Meter

A calibrated mechanical flow meter measures the WTS-LV pump exhaust for volume pumped. The cumulative meter reading cannot be reset. Flow meter calibration is in liters. To compare to the data recorded by the firmware, record the flow meter reading before deploying the WTS-LV and once again after recovery.



*Figure 2-14: Flow Meter*

## WTS-LV Toolkit

Each WTS-LV is shipped with a toolkit that contains the necessary tools, materials and devices to use the sampler. The toolkit and contents are referred to throughout this User Manual, and should remain with the instrument at all times.



*Figure 2-15: WTS-LV Toolkit*



The WTS-LV toolkit in Figure 2-15 is shown only as an example. Do not use the photo to compare with your actual toolkit contents.

## Serial Number

The WTS-LV serial number is printed on a label and attached to the controller housing. The pump assembly and system menu also display the serial number.

## Electronics

The WTS-LV firmware runs on the Persistor CF2 microcontroller. Older WTS-LV systems use the TattleTale 8 (TT8) microcontroller, which is discontinued. Most of this User Manual can apply to both current and older McLane instruments. However, significant firmware, hardware, and procedural changes were made to the WTS-LV with the CF2 microcontroller and some sections will not apply to older systems.



Contact [mclane@mclanelabs.com](mailto:mclane@mclanelabs.com) for information about upgrading from the TT8 to the CF2 microcontroller. McLane recommends this upgrade. We offer only limited support on devices that use the TT8 microcontroller.

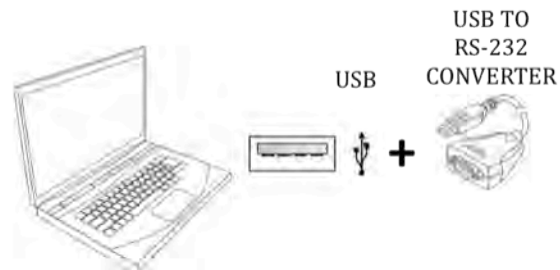
The WTS-LV electronics communicate using RS-232 serial communications and a terminal emulator, McLaneTerm. See Chapter 4 in this User Manual. “Getting Started” for more information about McLaneTerm which is provided with the system and must be installed on the computer that will connect to the WTS-LV. A communications cable included in the toolkit connects the WTS-LV controller with a computer. Computers that do not have a built-in RS-232 serial port use a USB to RS-232 converter that is also included in the toolkit.

### Computer COM Setup

Connection Style 1: Computers with Built-in Serial Port



Connection Style 2: Computers with USB, no Serial Port



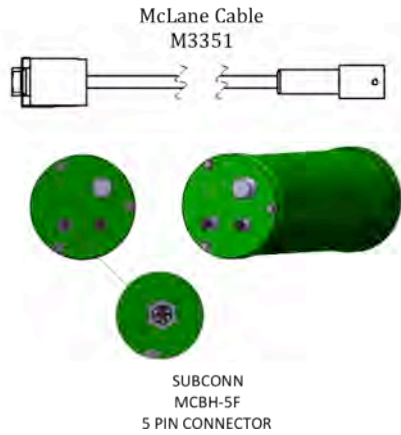
*Figure 2-16: USB Communications*

## Communications Bulkhead Connector Styles

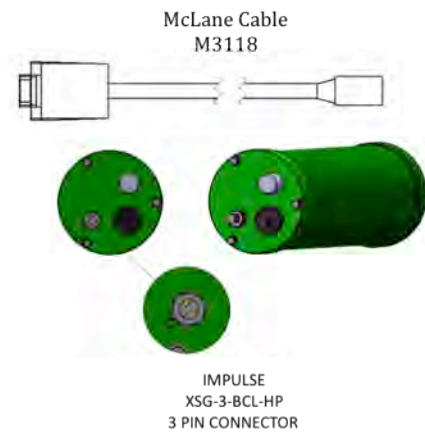
The communications cable bulkhead connector (connection to the sampler) is a 5-pin MCBH style. Some older instruments may have a 3-pin XSG style bulkhead connector.

### COM Cable Setup

Cable Style 1: Subconn 5-pin connector



Cable Style 2: Impulse 3-pin connector



*Figure 2-17: Communications Cable Connector Style*

## Main Battery

The standard model WTS-LV battery style is a battery holder for user replaceable ‘D’ cell alkaline batteries as shown in Figure 2-18. When inserting replacement ‘D’ cell batteries, be sure to **install the batteries with the correct orientation in the holder terminals**.

The Upright and Dual Filter WTS-LV models’ main battery is a high capacity battery pack (30,000 mAh capacity). Appendix A “WTS-LV Models” in this User Manual has more information about the 30,000 mAh A72-1000 battery pack.



*Figure 2-18: Main Battery Holder- Standard WTS-LV*

The instrument can perform pump operations while the system voltage is above 18 VDC. When the system voltage drops below 18 VDC, the instrument will enter low power sleep mode, and when awake, only limited functions will be available at the Main menu.

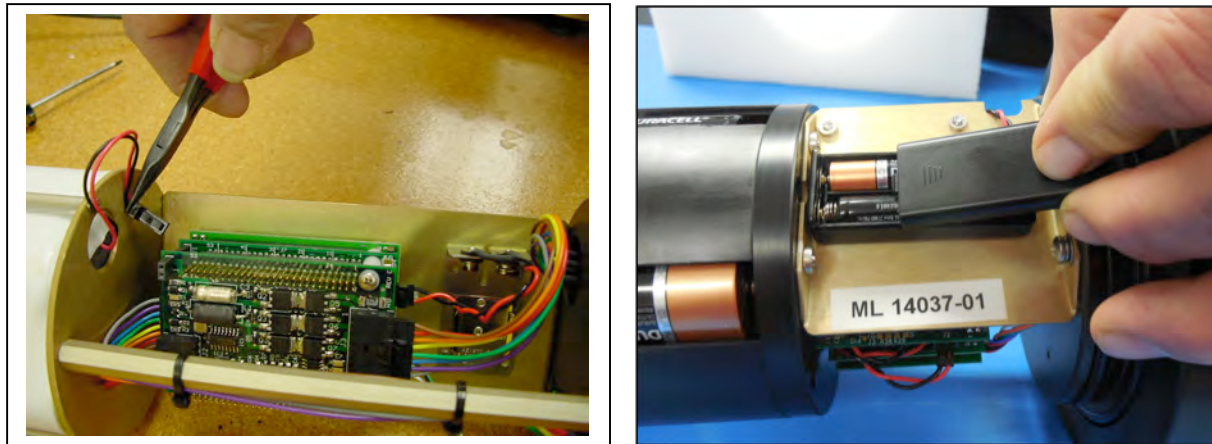


Always take standard electrostatic discharge (ESD) precautions when handling the electronics.

## Backup Battery

After the spring of 2015, new McLane CF2-based instruments no longer require a backup battery. Prior to this change, the backup batteries served as a voltage source for the electronics while in low power sleep mode. Electronics hardware changes made the backup battery unnecessary, and it was eliminated.

Check your system for backup batteries, if they are installed, be sure to replace them before each deployment. On the TT8 microcontroller based devices, the backup battery is a 9 volt battery mounted beside the electronics. On the Persistor CF2 microcontroller based devices, the backup battery is a plastic case with two AAA batteries mounted near the electronics.



*Figure 2-19: Backup Battery 9V and AAA Styles (Older Model WTS-LV systems)*

## Notes



# Chapter 3

## WTS-LV Deployment Description

### Deployment Overview

A WTS-LV deployment is made up of a single event. The user-programmable sample parameters are described below.

#### Procedure Parameters

Volume	Volume to be pumped during the procedure.
Flow Rate	The target flow rate of the procedure.
Min. Flow Rate	If filter loading has slowed the flow rate to the minimum flow rate, the procedure is terminated.
Time Limit	If the time limit is reached the procedure is terminated. The time limit is defaulted to the volume / minimum flow rate + 1 minute.

At the scheduled time of the pumping event, the system automatically wakes and begins sampling. Water flow moves through the horizontal intakes, and down into the filter holder through a titanium honeycomb baffle that straightens the flow and suppresses turbulence.

Water next passes through a 316SS wire pre-filter support. The filter holder evenly distributes the sample flow over the entire filter surface. Filtered water passes through the frit, down a short length of tubing, and through the pump to the exhaust port.

#### Sample Volume and Flow Rates

Flow rates are different based on the pump head and programmed volume.

Pump	Sample Volume	Flow Rate	Min. Flow Rate
4L/min	1 – 10000 liters	1000 – 5000 ml / min	500 ml / min
8L/min	1 – 20000 liters	4000 – 10000 ml / min	3000 ml / min
30L/min	1 – 50000 liters	12000 – 30000 ml / min	10000 ml / min

## Notes

# Chapter 4

## Getting Started

Topics Covered:

- Connecting to a computer.
- Installing and configuring McLaneTerm terminal emulation software on a computer.
- Powering up a McLane Sampler.
- Communicating with a McLane Sampler.
- Waking a McLane Sampler from low power sleep mode.

To complete the steps in this chapter, **you will need** the McLaneTerm software and McLaneTerm User Manual that shipped with the instrument.

### Connecting the Sampler to a Computer

Communicating with your instrument requires installing and configuring the terminal emulation program McLaneTerm, and connecting the communications cable to the computer.

#### Connecting a Computer

Connect to the instrument by plugging the communications cable from the communications bulkhead on the end cap to a computer RS-232 serial port (the toolkit includes a USB to RS-232 adapter for computers without the built-in RS-232 port). Plug the adapter into the USB port, wait for the drivers to install, and then check the computer's Device Manager for the new USB Serial Port. Windows typically downloads and installs the necessary drivers automatically when the USB to RS-232 adapter is plugged into a USB port.



*Figure 4-1: Communications Cable*

## Troubleshooting the USB Adaptor

The USB adaptor has LED indicator lights for transmitting and receiving data. Typing any key in terminal emulation should be indicated by the LED. If no LED light flashes on keystrokes, you may have selected the incorrect COM Port.

## **Installing and Configuring McLaneTerm**

**McLaneTerm** is a terminal emulation program for Microsoft Windows and Mac OSX platforms used to communicate with serial McLane instruments. With McLaneTerm, you can interact with your McLane instrument's text based interface while it is connected to a serial port on your computer. McLaneTerm replaces the terminal emulation tools MotoCross (for CF2) and CrossCut (for TT8).



Creating capture files of all commands and responses with your McLane instrument is a customer best practice that is critical for successful technical support.

To follow this section, you will need the McLaneTerm software and McLaneTerm User Manual that was included on the instrument's USB drive. McLaneTerm software and the User Manual can also be downloaded at our website [www.mclanelabs.com](http://www.mclanelabs.com).

- McLaneTerm uses standard Windows and Mac OSX automatic installation programs. Follow the McLaneTerm User Manual if you need instructions to install McLaneTerm on a computer.
- In the McLaneTerm User Manual, follow the sections “Settings” and “Using Commands” to properly setup McLaneTerm software.
- When communication with your McLane instrument is established, proceed to the section that follows next in this User Manual “Powering up the Sampler”.



**McLaneTerm system requirements:** Windows® 7 or higher / Mac OS X version 10.7 (Lion) or higher.

## Powering up the Sampler

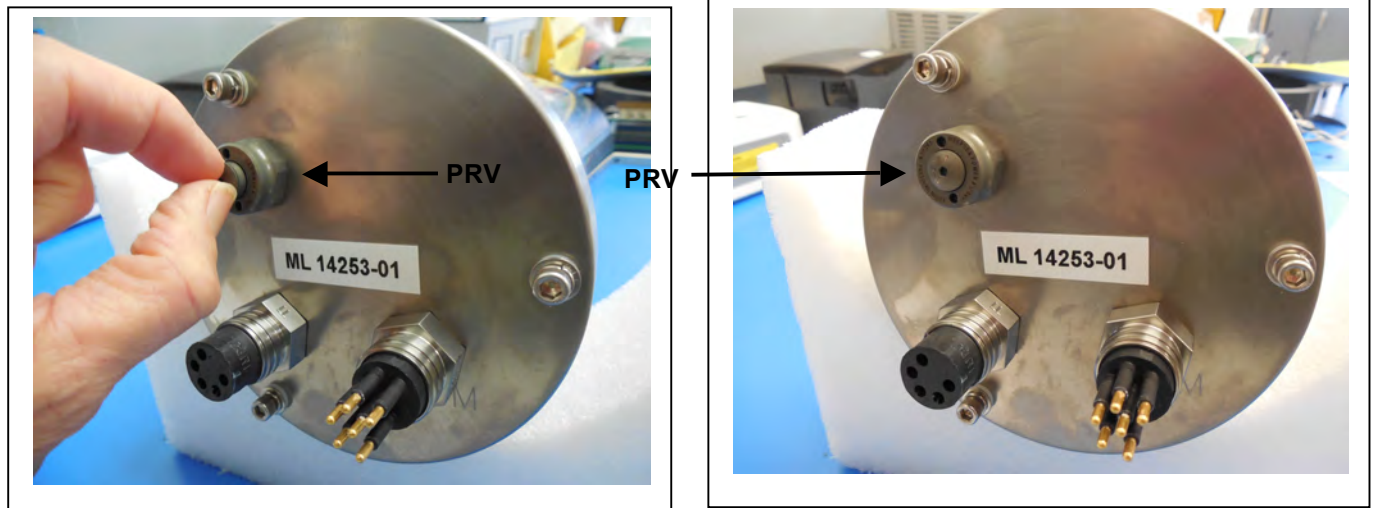
Connecting the battery is the only way to power on the sampler electronics. This step requires opening the controller housing. Be sure to perform this procedure in a dry area and familiarize yourself with steps for using the Pressure Relief Valve.

### Opening the Controller Housing

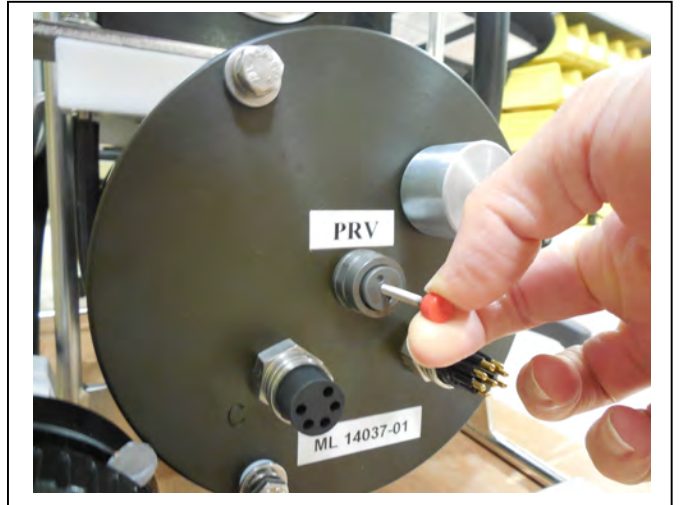
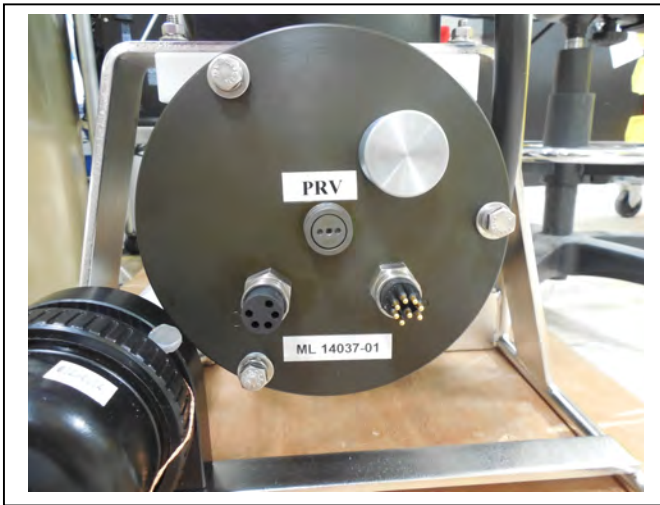
Attention and care should be taken in maintaining, operating, and opening the pressure housing. All samplers shipped after summer 2015 have a pressure relief valve (PRV) on the controller housing. This valve releases automatically at a pressure differential greater than 10psi. The PRV style may have a center hole and release tool, or the style may have a flat relief valve that must be manually pulled out.



Observe safety precautions including removing personnel and objects from the path of the end-cap when removing the controller housing.

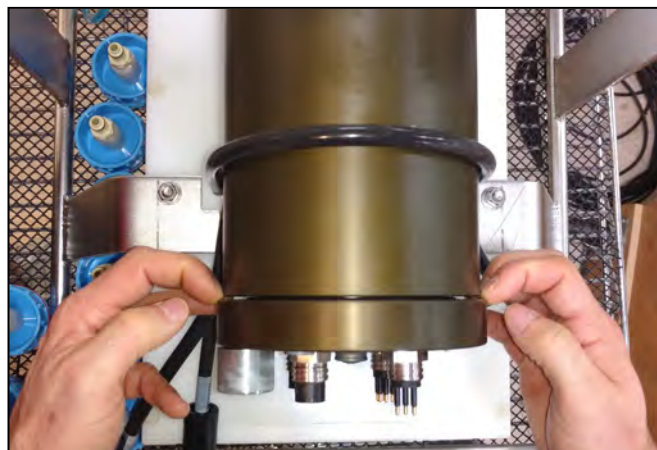


*Figure 4-2: Releasing Pressure Relief Valve (Flat Style)*



*Figure 4-3: Releasing Pressure Relief Valve (Style with Release Tool)*

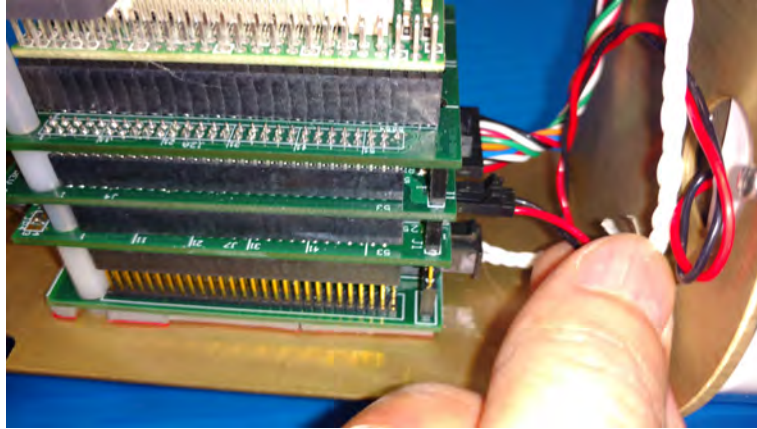
1. Disconnect the cables from the end cap (if connected).
2. Slowly pull on the pressure relief valve to release any vacuum or built up pressure in the housing.
3. Loosen each end cap bolt a few turns at a time in a star pattern.
4. If the end cap separates from the housing as you loosen the bolts, this could indicate a possible pressure buildup inside of the housing. Stop loosening bolts and continue to gently pull on the pressure relief valve.
5. Remove and place the end cap hardware somewhere safe. Typically plastic inserts have a snug fit and will remain in the end cap.
6. Grasp the end cap lip with fingertips and pull the end cap out of the housing (Figure 4-4). The end cap to housing seal is tight and sometimes difficult to open. Do not use a tool to pull open the housing. The end cap o-rings can be damaged if objects are used to separate the end cap from the housing.



*Figure 4-4: Separating the Housing and End Cap*

## Connecting the Batteries

Locate the battery conductors. The black two pin MTE connector will only fit into one connector on the electronics stack. Find the two pin female connector that mates with the battery connector on the Aux / Stepper board and plug in the batteries.



*Figure 4-5: Connecting the Battery*



Backup batteries are not installed with firmware v2.05 and higher. Electronics hardware changes made the backup battery unnecessary and it was eliminated. If deploying a WTS-LV that still has a backup battery, install a fresh battery before every deployment.

## Establishing Communication with the Firmware

Once the battery is connected and the terminal emulation software is installed, communication with the sampler firmware can be made.

1. Find the communication cable provided in the toolkit.
2. Connect the communications cable to the computer serial communication port before connecting to the communications connector on the controller end cap.



*Figure 4-6: Connecting the COM Cable*

3. Align the bulkhead connection pins, and push the bulkhead in place on the controller end cap.
4. On the computer, open a properly configured McLaneTerm window.
5. Connect the DB9 end of the communication cable to the computer communication port configured in McLaneTerm.
6. Enter [CTRL]-[C] in McLaneTerm. If the computer setup procedures were completed correctly, the Main Menu, a system clock confirmation message, or a message that indicates the system is Suspended will print to the screen.



## Waking the Sampler from Low Power Sleep Mode

The sampler will enter a low power mode if it sits idle for more than 20 minutes. To wake the system from this suspended state, hold down [CTRL]-[C]. After five seconds of holding down [CTRL]-[C] (or using the Wake up button on McLaneTerm), the Main Menu will display (Figure 4-7).

If [CTRL]-[C] is held down for more than 5 seconds and nothing happens, check the previous sections of this chapter to make sure procedures were followed correctly. If your system has backup batteries, confirm they are properly seated in the backup battery housing, and make sure they are plugged into the electronics.

```
-----  
CF2-LV-2.10 | LV-2_10.c   compiled Jan 11 2018 at 16:21  
LV-8M_TR  S/N ML12345-01  Large Volume Sampler  
© 1998-2018 McLane Research Laboratories. All rights reserved.  
-----  
Clock reads 03/09/18 11:07:57.  Change [N] ?  
  
-----  
Configuration: LV-8M_TR           CF2 V2_10 of Jan 11 2018  
                McLane Research Laboratories, Inc.  
                Large Volume Sampler  
                ML12345-01  
  
-----  
                Main Menu  
-----  
                Fri Mar  9 11:08:28 2018  
  
                <1> Set Time           <5> Deploy System  
                <2> Diagnostics       <6> Offload Data  
                <3> Manual Operation  <7> Contacting McLane  
                <4> Sleep             <C> Configure
```

Figure 4-7: Main Menu

## Notes

# Chapter 5

## User Interface

This chapter introduces the user interface including the Main and Configuration Menus, and explores some basic functions of the WTS-LV menu driven user interface.

Topics covered:

- WTS-LV Menu System.
- System Configuration.
- Setting the System Time.
- System Diagnostics.

### Main Menu

The Main Menu automatically displays after firmware initialization. The pump head, enabled options, firmware version and compile date display at the top of each firmware screen. The options on this menu are explained in more detail at the end of this chapter.

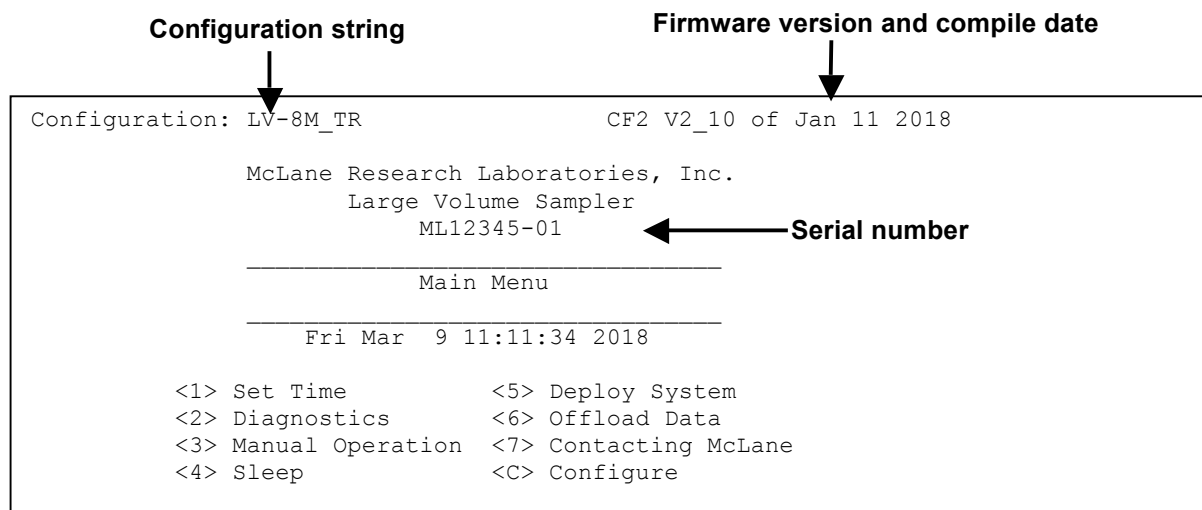


Figure 5-1: WTS-LV Main Menu

- **Configuration String:** The configuration string indicates the current instrument configuration. The configuration string in Figure 5-1 indicates the WTS-LV has an 8L/min Maxon pump, and the Trigger option is active.
- **Firmware Version and Compile Date:** The currently running firmware version and the compile date are displayed on the top right corner of the main menu.
- **Serial Number:** The McLane Serial Number can be found on the Main Menu and should be included in all system inquiries to McLane Research Labs.

## <1> Set Time

The set time menu option allows you to program the system real time clock (RTC). McLane recommends setting the RTC during the power-up sequence. When the WTS-LV is powered on, the clock defaults to January 1, 1970, 00:00:00. The clock can be set to any date and time in the allowed range and the count will continue from the new value.

To set the time:

1. Select the Set Time menu option.
2. Enter the date and time using the provided format.
3. Accept the changes to the system clock.

```
Clock reads 01/01/70 00:15:39.  Change [N] ? y
Format is mm/dd/[yyyy or yy] hh:mm:ss
Enter correct time [01/01/1970 00:15:41] ? 03/13/2015 08:32:19
Clock reads 03/13/15 08:32:19.  Change [N] ?
```

*Figure 5-2: Set Time*

## <2> Diagnostics

The Diagnostics menu option will continuously print system data to the screen. The data printed to the screen will vary between system configurations, but always includes the date, time, main battery voltage, and the temperature according to the thermistor on the system electronics. Diagnostics data printed to the screen can be paused and resumed by entering any key into McLaneTerm (terminal emulation). Exit and return to the main menu by entering [CTRL]-[C].

```
Selection [] ? 2

  Press any key to pause/continue display, or ^C to exit

03/13/15 08:33:16 35.8 Vb 21°C
03/13/15 08:33:17 35.8 Vb 21°C
03/13/15 08:33:18 35.8 Vb 21°C
03/13/15 08:33:19 35.8 Vb 21°C
03/13/15 08:33:20 35.8 Vb 21°C
03/13/15 08:33:21 35.8 Vb 21°C
03/13/15 08:33:22 35.8 Vb 21°C
03/13/15 08:33:23 35.8 Vb 21°C
```

*Figure 5-3: Diagnostics*

## Battery Warnings

- Low battery voltage triggers warning messages during the exit from Diagnostics. If the main battery falls below 20 V, a message displays to replace the battery before deployment.
- If the main battery falls below 18 V, the Diagnostics program terminates and displays the message below before returning to the Main Menu.
- If a critically low battery is detected and a data file exists in memory that has not been offloaded, an additional warning displays reminding the user to offload data.

## <3> Manual Operations

Manual Operation provides direct control of the pump for bench testing, system assessment, and deployment preparation (the examples that follow show a 4L/min pump).

- **Manual Pumping Operations:** Options 1– 3 of the WTS-LV Manual Operation Menu allows the user to perform manual pumping operations based on predefined, or user-defined pumping parameters. The pump can be stopped at any time by pressing [CTRL]-[C]. Forward and reverse directions pump 5 liters of water at 3L/min, or 10 liters of water at 7L/min.

```
-----  
Configuration: LV-8M_TR                CF2 V2_10 of Jan 11 2018  
  
-----  
Manual Operation  
-----  
Fri Mar  9 11:12:02 2018  
  
<1> Run pump forward (10 liters @ 7 L/min)  
<2> Run pump reverse (10 liters @ 7 L/min)  
<3> Run pump programmable  
  
<M> Main Menu  
  
Selection [M] ?
```

*Figure 5-4: Manual Operation Menu – Configured for 8L/min Pump Head*



Do not run the pump dry. If conducting a bench test, submerge the WTS-LV intake and exhaust lines in water.

## <4> Sleep

The WTS-LV automatically enters Sleep (Suspend) mode if left idle for 20 minutes to suspend the drain of battery power. You can also put the WTS-LV in Suspend mode indefinitely by selecting the <4> Sleep option of the Main Menu. Prior to Suspend mode, the current time will display. During Suspend mode, the system will wake every 20 minutes to check system status, display the time and then return to Suspend mode. To wake the system and return to the Main Menu, hold down [CTRL]-[C] until the system wakes up.

```
Selection [ ] ? 4  
  
03/09/18 11:28:51 Suspended ...
```

*Figure 5-5: Suspend/Sleep Mode*

## <5> Deploy System

The Deploy System menu option will check and reset the scheduled or count-down start mode. The system will perform pre-deployment system checks, and put the sampler into low power sleep mode until the scheduled event time. System deployment is described in more detail in Chapter 6, “Deployment Preparation”.

## <6> Offload Data

The Offload Data menu option will print the data gathered during a deployment to the screen. Users can capture this data by setting up a capture file in McLaneTerm. Offloading data is described in more detail in Chapter 6, “Deployment Preparation”.

## <7> Contacting McLane

This option displays McLane Contact information and includes the software version and serial number of your instrument.

```
Selection [] ? 7

McLane Research Laboratories, Inc.
  Falmouth Technology Park
  121 Bernard E. Saint Jean Drive
  East Falmouth, MA 02536-4444 USA

Email: McLane@McLaneLabs.com
Web: http://www.McLaneLabs.com
Tel: 508-495-4000 Fax: 508-495-3333

Configuration: LV-8M_TR
Source file: CF2-_10.c 01
Electronics S/N: ML12345-01
Compiled: Jan 11 2018 16:21

Press any key to continue.
```

*Figure 5-6: McLane Contact Information*

## Configuration Menu

McLane properly configures the instrument before shipping. Reconfiguration may be necessary if the pump head is changed, the system firmware is updated, or the trigger is disabled.

```
Configuration: LV-8M_TR                CF2 V2_10 of Jan 11 2018

-----
Configuration Menu
-----
Fri Mar 9 11:44:21 2018

<A> Integral Pressure Sensor           [No]
<B> Pump                               [Maxon 8 L/Min.]
<C> Rechargeable Battery              [No]
<D> Trigger                            [Enabled]

<X> Save & Exit                        <^C> Cancel & Exit
```

*Figure 5-7: Configuration Menu*



## Configuring the System

1. Type *C* at the Main Menu and when prompted for a password enter “*CON*”.
2. Use menu option *A* to select whether an integral pressure sensor is installed (this option is purchased separately for the WTS-LV) and “No” is the default setting.
3. Use menu option *B* to select the system pump head capacity and pump motor manufacturer. The firmware settings must match the installed pump head. Contact McLane ([mclane@mclanelabs.com](mailto:mclane@mclanelabs.com)) with your serial number before changing this value.
4. Use menu option *C* to change to rechargeable battery mode (contact McLane before using this option). WTS-LV samplers with drop-in battery holders can hold 24 D cell alkaline batteries or rechargeable batteries (or rechargeable battery packs). Discharge specifications vary by battery manufacturer. The WTS-LV stops pumping and goes to Sleep mode at the minimum discharge value.

**Option A:** Keep the default rechargeable battery minimum and warning values.

**Option B:** Enter different values based on specific rechargeable batteries in use.

```
Configuration: LV-8M                               CF2 V2_10 of Jan  3 2018
-----
                        Configuration Menu
-----
                        Sat Aug 26 07:17:31 1978
<A> Integral Pressure Sensor      [No]
<B> Pump                          [Maxon   8 L/Min.]
<C> Rechargeable Battery         [No]
<D> Trigger                       [Disabled]
<X> Save & Exit                   <^C> Cancel & Exit

                        Selection [ ] ? c
Is there a rechargeable battery installed? [N] ? y

Battery Warning: 32.0V, Battery Minimum: 24.0V
Adjust warning and minimum battery voltages? [Y] ?

<A> Use default values [32.0, 24.0]
<B> Enter manufacturer recommended values
<C> Return to configuration menu

                        Selection [A] ? b

Enter rechargeable battery warning voltage (+10.00 to +36.00) [+32.00] ? 29
Enter rechargeable battery minimum voltage (+9.00 to +28.00) [+24.00] ? 19

NOTE: Configured for rechargeable batteries
Battery Warning: 29.0V, Battery Minimum: 19.0V
```

*Figure 5-8: Configuration for Rechargeable Batteries*

5. Use menu option D to disable or activate the trigger start. A trigger start provides a way to time synchronize multiple instruments. If the Trigger option is used, the WTS-LV sampler must have the trigger plug installed. The firmware does not check to verify whether the trigger is installed regardless of the setting on the Configuration menu.

# Chapter 6

## Deployment Preparation

Topics covered:

- Closing and sealing the controller housing.
- Installing Filters and Priming – Radial Intake Filter Holders.
- Installing Filters and Priming – Vertical Intake Filter Holders.
- Installing the water flush filter.
- Estimating Instrument Current Consumption.
- Programming a deployment.
- Starting a deployment.

Examples in this chapter show the filter holder removed from the WTS-LV. However, for priming, the filter holder should remain installed on the frame with the tubing between the filter holder and the pump connected.

### Closing and Sealing the Controller Housing

Before priming, the controller housing end cap should be closed and sealed. Always inspect o-rings for signs of wear and the presence of any foreign material (which can cause leaks). Look for small cracks and feel for grit, sand, or hair. Clean o-rings with alcohol and lubricate with a thin coating of o-ring grease as necessary.

See Chapter 2, “System Description”, for details about placement of the end cap and o-rings, which is critical. Position the larger o-ring in the axial groove to seal against the face end of the pressure housing. Fit the smaller o-ring and the backup ring in the radial groove. Position the backup ring on the low pressure side of the radial groove (toward the interior of the controller housing). The backup ring concave side faces toward the round o-ring. The accompanying o-ring is seated on the concave side (high pressure side) of the backup ring.

### Checking the Zinc Anodes

Inspect, and if necessary, replace the zinc anodes attached to the controller housing top and bottom end caps. When installing new zinc anodes, use 316 stainless steel hardware and include the o-ring. Spare zincs can be ordered from McLane.

## Priming the WTS-LV

Priming is an important deployment preparation step. Priming steps vary according to WTS-LV model and filter holders. The sections that follow explain the recommended processes for installing filters and priming the radial intake and vertical intake filter holders. If priming a Dual Filter WTS-LV sampler, see Appendix A, section A.1 in this User Manual for guidelines

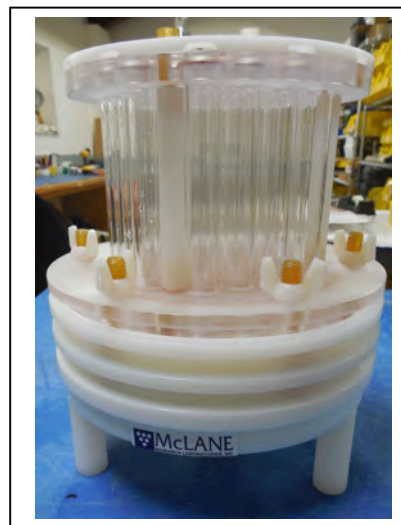
There are several methods for priming a standard WTS-LV. The ultimate priming goal is to clear trapped air from the tubing between the pump and filter holder by flooding the tubing with water. Prime when new filters are added, which can introduce air to the system. This step is especially important when using filters with smaller porosity.



When selecting your customer-supplied filters, the pump head size and filter porosity must be compatible. For example, the 4L/min pump head is the only pump head size compatible with a more restrictive filter such as 0.2  $\mu\text{m}$ . Refer to Appendix C in this User Manual, 'Pump Head Sizing' for a detailed chart.



*Figure 6-1: Radial Intake Filter Holder*



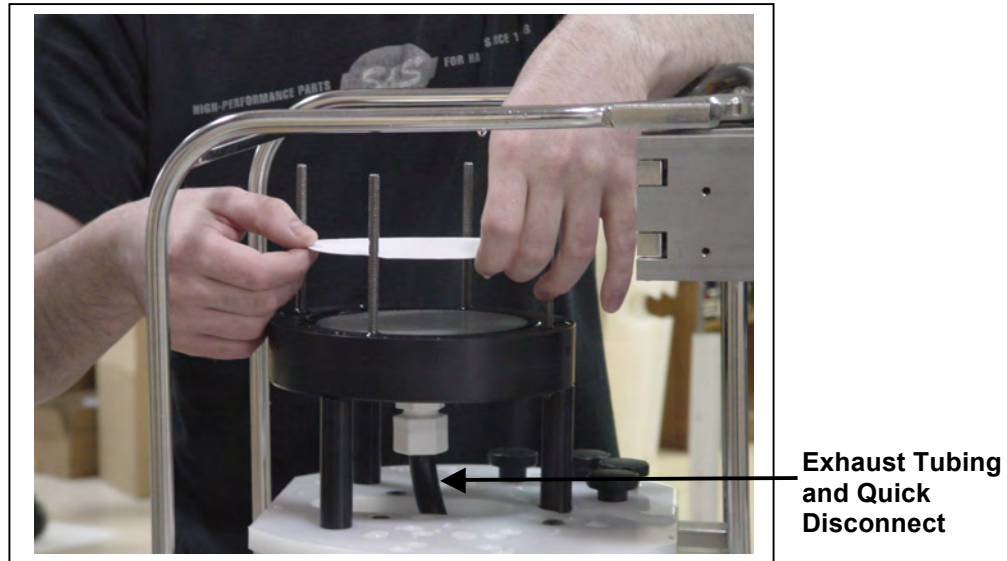
*Figure 6-2: Vertical Intake Filter Holder*

Priming is a wet process. Required tools for priming are included in the tool kit:

- 500mL squirt bottle (to wet the frit and filter).
- Exhaust hose with quick disconnect fitting.

## Installing Filters and Priming - Radial Intake Filter Holders

For demonstration purposes, the photos in this section show the radial intake filter holder uninstalled from the frame. The filter holder should be on the frame when performing this procedure.

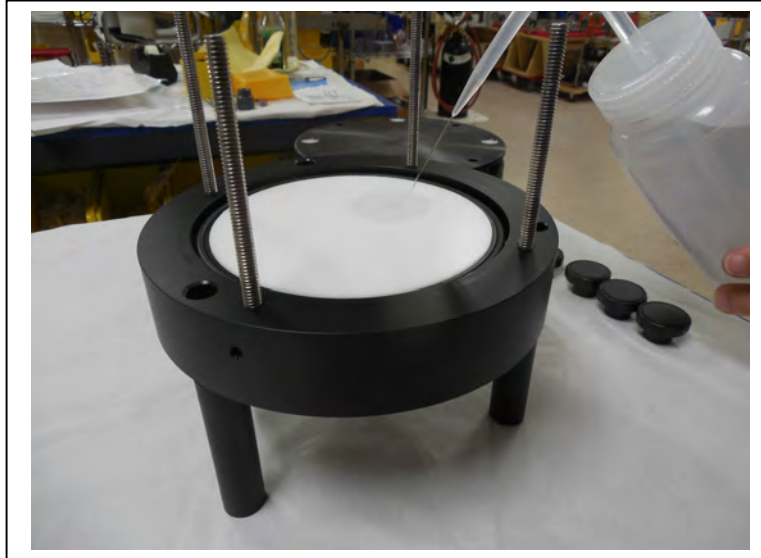


*Figure 6-3: Tubing and Quick Disconnect*

To prime and install filters, complete the following steps. Complete these steps with the filter holder installed in the WTS-LV system):

1. Locate the exhaust hose tubing with the quick disconnect from the toolkit.
2. Attach the fitting to the underside of the radial intake filter holder, which should be installed on the WTS-LV frame. The exhaust hose assists in helping to keep the line primed and will remove excess air. This is critical when using a filter with a fine (restrictive) porosity.
3. Unscrew the four knurled nuts at the top of the filter assembly. Remove the filter holder top and any pre-filter plates until the filter holder bottom plate remains.

4. Fill the 500mL squirt bottle with neutral water and flood the filter holder bottom plate. As the space below the frit is filled with water, puddles will form on the porous frit service. This puddling indicates the exhaust tubing is filling with water and pushing out any air bubbles.



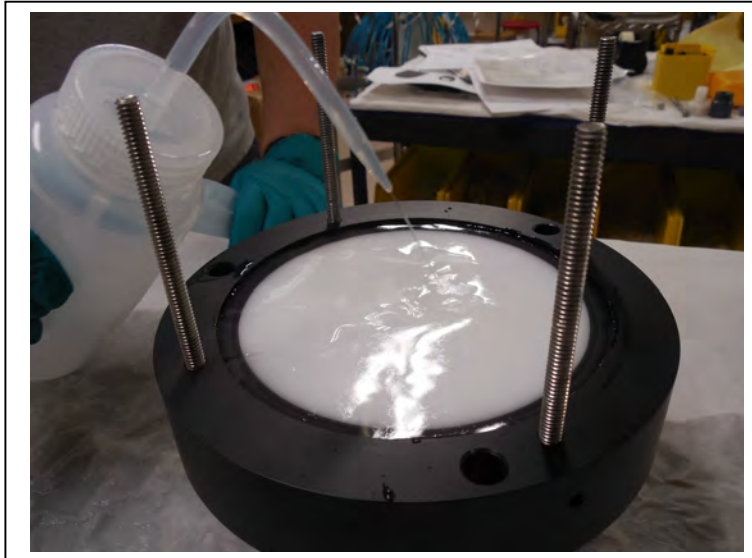
*Figure 6-4: Wetting the Bottom Filter Holder Plate*

5. Place a 142mm filter (customer supplied) onto the filter holder bottom plate.



*Figure 6-5: Placing the Filter on the Bottom Filter Holder Plate*

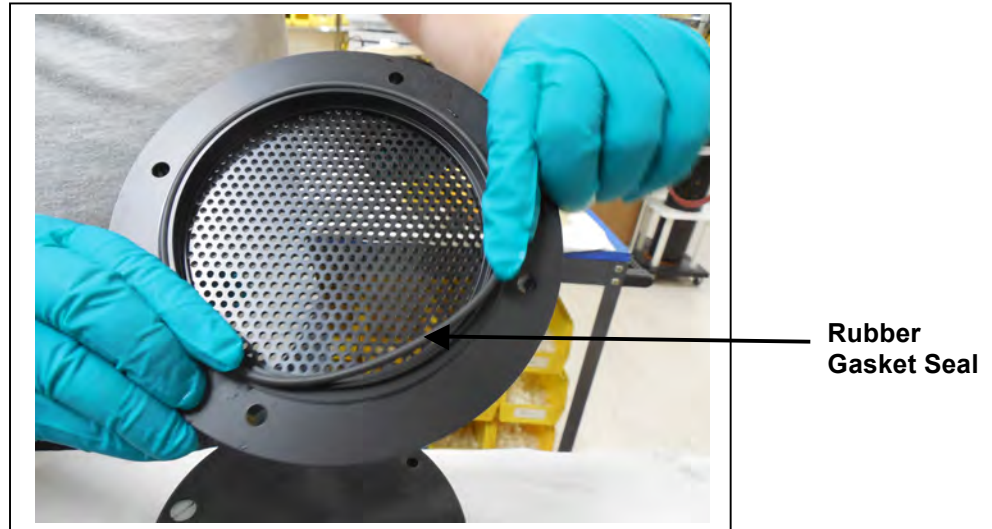
6. Wet the filter with water from the squirt bottle. Confirm that the filter is flat and centered on the filter holder plate by gently moving the filter and pressing down lightly to displace trapped air.
7. Allow water to saturate the membrane from below



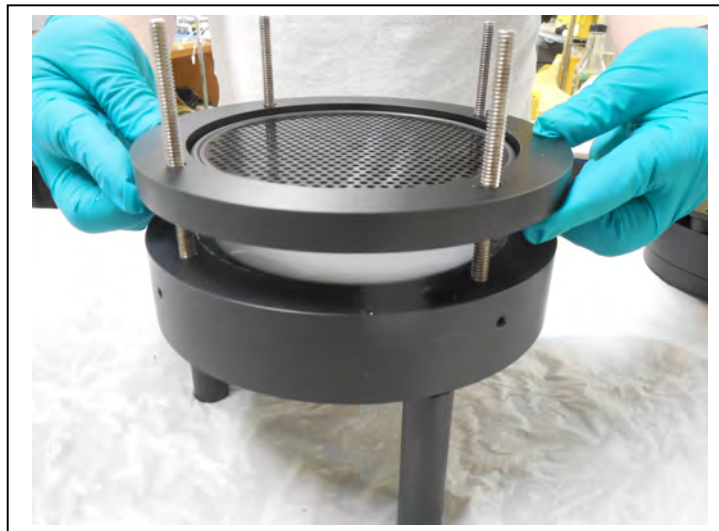
*Figure 6-6: Soaking the Installed Filter*

8. Repeat this process for each filter holder tier.

9. Install the pre-filter plate. Ensure that both the upper and lower o-rings are seated correctly.



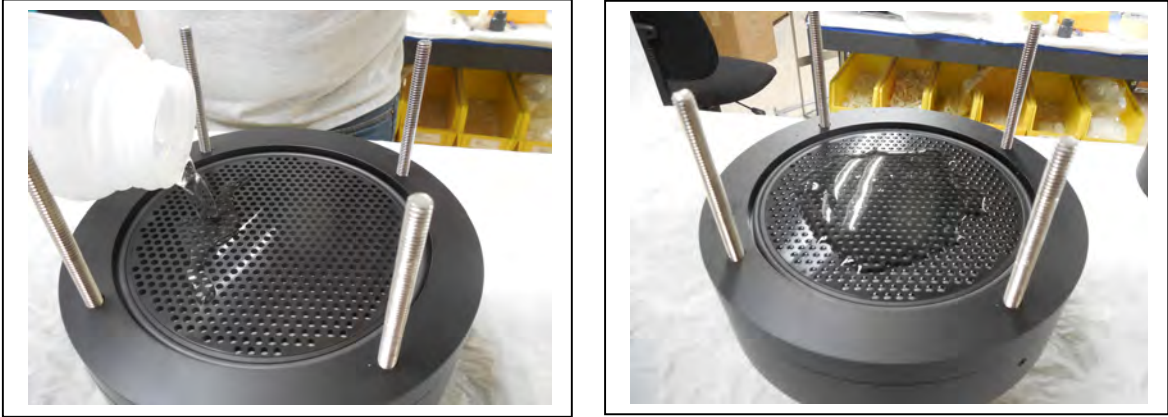
*Figure 6-7: Seating the Pre-Filter Plate Rubber Gasket*



*Figure 6-8: Placing the Pre-Filter Plate on the Filter Holder*



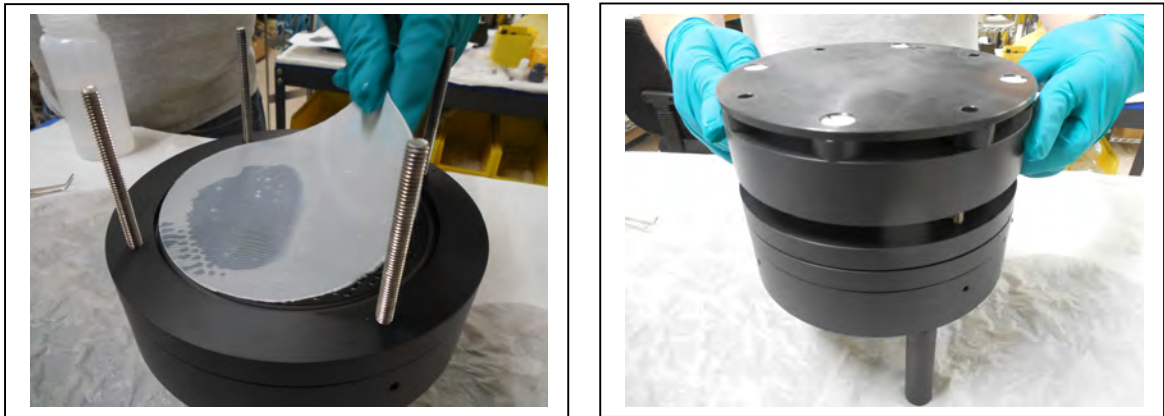
10. Fill the pre-filter plate with neutral water until a pool forms on the plate surface.



*Figure 6-9: Fill the Pre-Filter Plate until Water Pools*

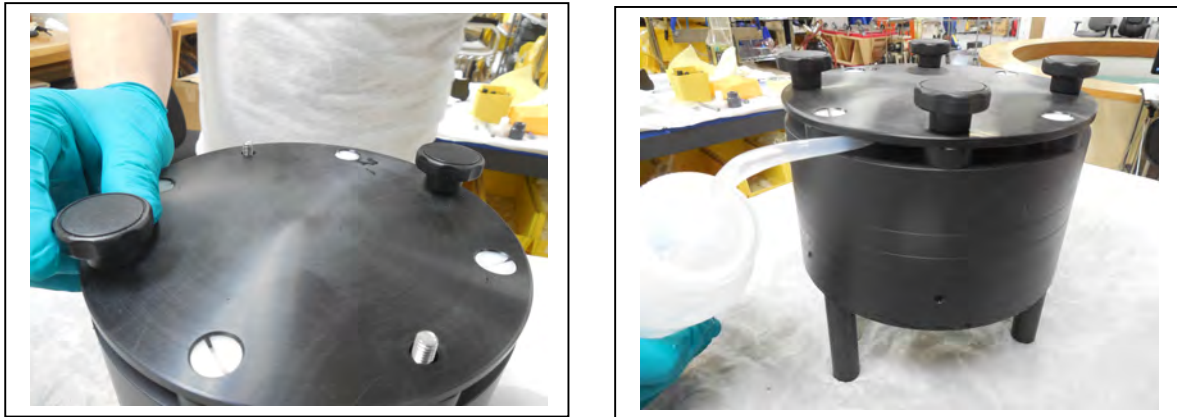
11. Install a 142mm mesh pre-filter (customer supplied) and flood the top of the pre-filter with water.

12. Place the top section on the filter assembly.



*Figure 6-10: Install Filter and Top Section*

13. Install and tighten the four knurled nuts.
14. Fill top of the filter assembly with neutral water prior to deployment.



*Figure 6-11: Tighten Nuts and Fill Assembly with Neutral Water*

### Correct Filter Plate Assembly

A correctly secured filter holder assembly will not have gaps between the plates. Use the knurled nuts to tighten the plates until they are closed without gaps. Figures 6-12 and 6-13 show examples of the 3-tier filter holder. The correct assembly for the standard filter holder has one less filter holder section.



*Figure 6-12: Correctly Closed Filter Holder*



*Figure 6-13: Incorrectly Closed Filter Holder*

## Installing Filters and Priming - Vertical Intake Filter Holders

For demonstration purposes, the photos in this section show the vertical intake filter holder uninstalled from the frame. The filter holder should be on the frame when performing this procedure.



*Figure 6-14: Vertical Intake Filter Holder*

To install filters and prime with the vertical intake filter holder, complete the following steps:

1. Locate the exhaust hose tubing with the quick disconnect from the toolkit.
2. Attach the fitting to the underside of the vertical intake filter holder, which should be installed on the WTS-LV frame. The exhaust hose assists in helping to keep the line primed and will remove excess air. This is critical when using a filter with a fine porosity.
3. Unscrew the six wing nuts located at the top of the filter assembly. Remove the filter holder top and any pre-filter plates.

4. Fill the 500mL squirt bottle included with the tool kit with neutral water. Flood the filter holder bottom plate. Water will eventually pool on the porous surface when the space below the frit has filled completely.



*Figure 6-15: Flood the Filter Holder Bottom Plate*

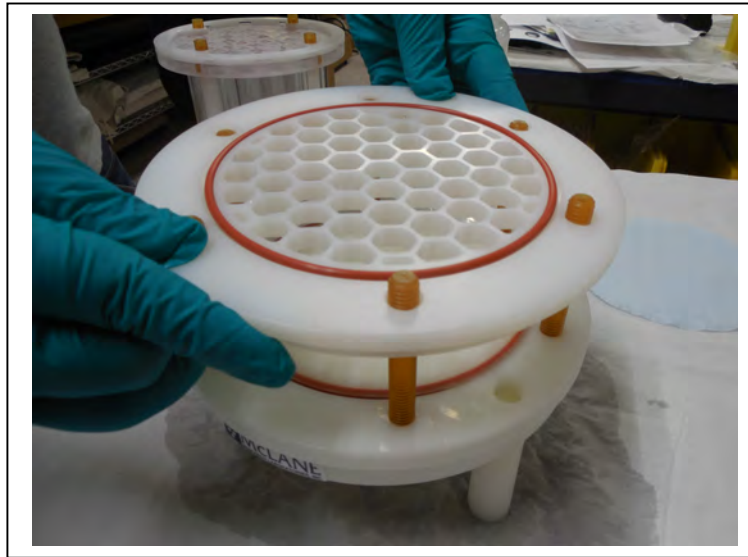
5. Place a 142mm filter onto the filter holder bottom plate.
6. Confirm that the filter is flat and centered on the filter holder plate by gently moving the filter and pressing down lightly to remove trapped air.



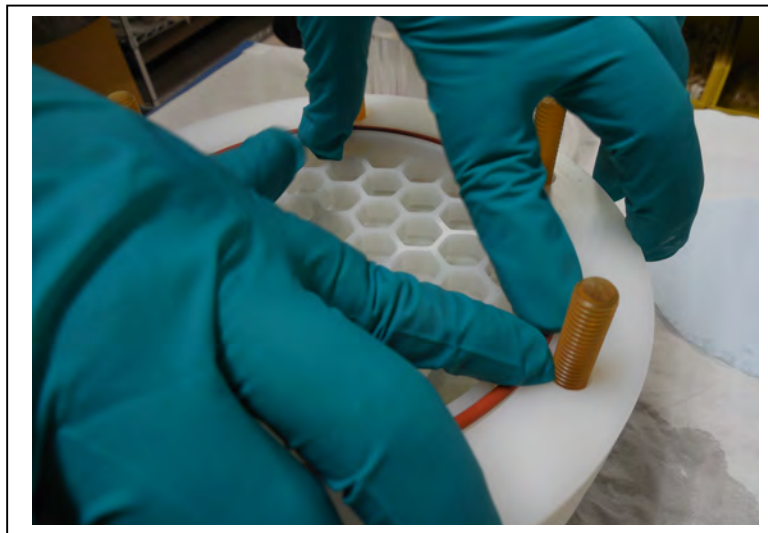
*Figure 6-16: Placing the Filter onto the Filter Holder Plate*

7. Allow water to saturate the membrane from below and then flood top of the filter with water.

8. Install the pre-filter plate. Ensure that the o-ring seal is seated in the groove.

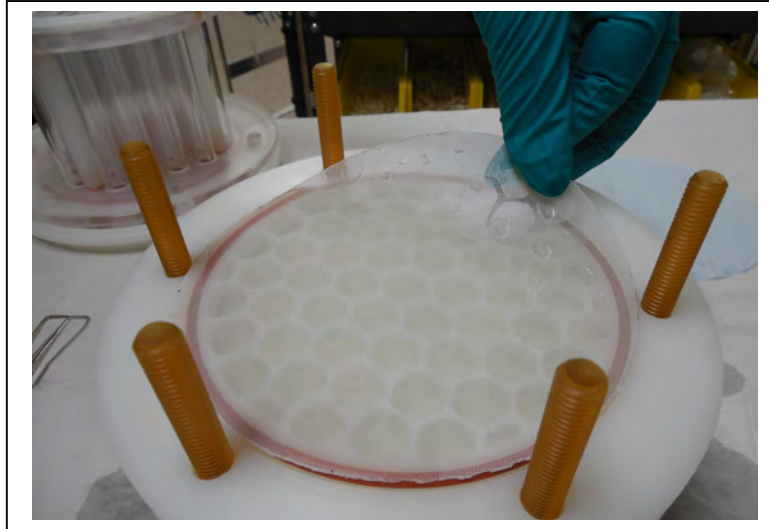


*Figure 6-17: Installing the Pre-Filter Plate*

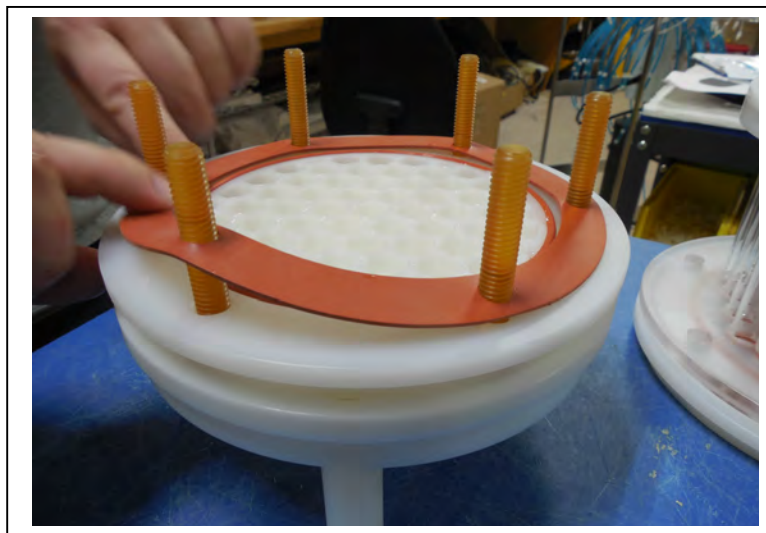


*Figure 6-18: Secure Seal in Plate Groove*

9. Install a 142mm mesh pre-filter and flood the top of the pre-filter with water. If the pre-filter is made from coarse material, it may also be necessary to install the optional gasket seal on the pre filter plate (Figure 6-19).

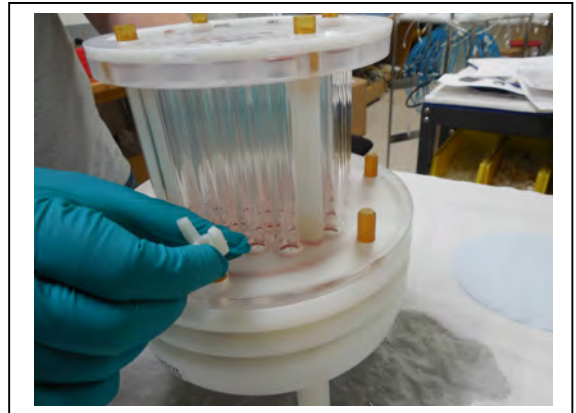
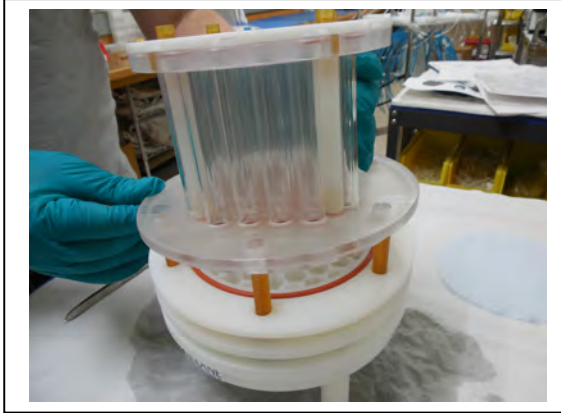


*Figure 6-19: Installing the Pre Filter*

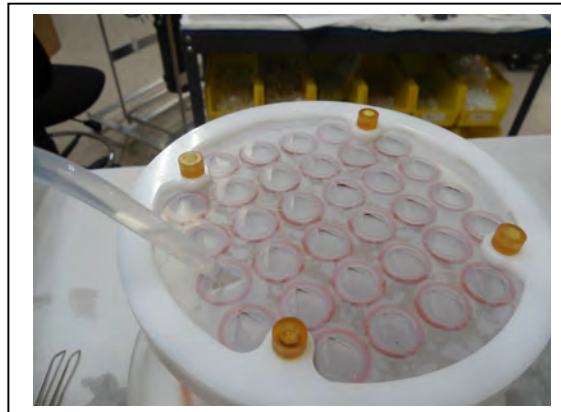


*Figure 6-20: Installing the Optional Gasket to Seal the Pre Filter*

10. Place the top section on the filter holder and evenly tighten the six wing nuts.
11. Fill the top of the filter holder with neutral water prior to deployment.



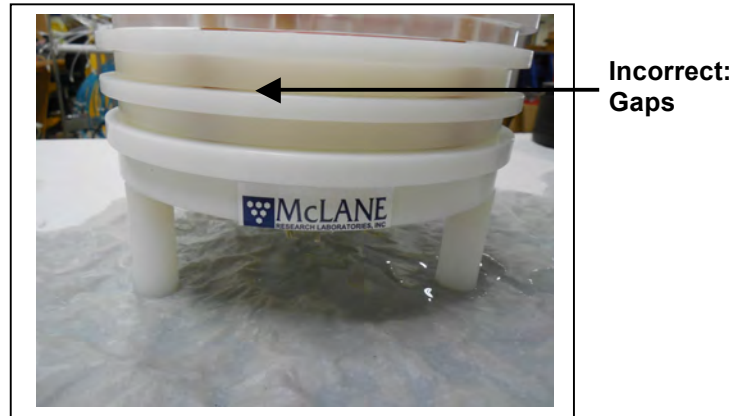
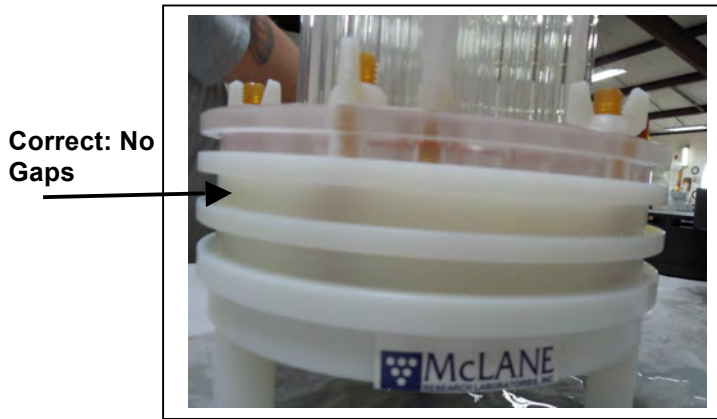
*Figure 6-21: Install Filter Top and Tighten Wing Nuts*



*Figure 6-22: Fill the Filter Holder Assembly with Neutral Water*

## Correct Filter Plate Assembly

A correctly installed filter holder assembly will not have gaps between the plates. Use the wing nuts to tighten the plates until they are closed without gaps.



*Figure 6-23: Correctly Closed Filter Holder*

*Figure 6-24: Incorrectly Closed Filter Holder*



## Estimating Instrument Current Consumption

Battery life for a planned Standard WTS-LV deployment can be estimated using the instrument current consumption values provided here. These values apply to the CF2 microcontroller. An 8L/min pump operated at 7L/min is used for the example. The 24 alkaline “D” cells in the drop-in battery holder deliver approximately 10,000 mAh. In addition to pumping time, many other deployment conditions can affect the battery duration. Use this example for estimation only.

- Pre-deployment battery estimate assumes initial setup steps and does not include bench testing or running diagnostics.
- Pumping assumes unrestricted flow.

<b>Pre-deployment</b>	
Controller (1 hour)	1 h x 15 mA = 15 mAh
Pumping (0.2 hour)	0.2 x 750mA = 150 mAh
	<b>Subtotal = 165 mAh</b>
<b>Deployment</b>	
Controller (6 hours)	6 h x 15 mA = 90 mAh
Pumping (6 hours)	6 h x 750 mA = 4500 mAh
	<b>Subtotal = 4590 mAh</b>
<b>Recovery</b>	
Controller (1 hour)	1 h x 15 mA = 15 mAh
	<b>Subtotal = 15 mAh</b>
<b>Total Current Consumption</b>	<b>Total = 4,770 mAh</b>

This example shows that the total energy consumed is 4,770 mAh, which will not exceed the 10,000 mAh battery life.

The WTS-LV Upright and Dual Filter models’ A72-1000 battery has a 30,000 mAh capacity. Use 30,000 mAh as the capacity rather than 10,000 mAh when estimating battery endurance for these WTS-LV models. Sample battery endurance estimates for these WTS-LV models are in Appendix A of this User Manual.

## Programming Deployment Parameters

After the system has been inspected and primed, the next step in preparing for a deployment is programming the Deployment Parameters. Follow the steps in this section to program the WTS-LV Deployment Parameters.

1. Establish communications with the WTS-LV, and start a capture file named "DEPLOYMENT\_PREP\_[DATE\_AND\_TIME]".
2. Select Main Menu option <5> Deploy System. There will be system warnings if there are previous deployment records in memory, if the system hasn't been rebooted since the last deployment event completed, or if battery voltages have dropped below the system warning voltage. These warnings are self-explanatory. Follow the prompts to continue the deployment.
3. Confirm that the system clock is correct (McLane firmware uses a 0-24 military time convention).

```
Selection [] ? 5
Clock reads 03/09/18 11:44:33. Change [N] ?
-----
Header  1|
        2|
        3|
Sample  4| Sample volume   =      300 [liters]
        5| Initial flow rate =      7000 [ml/min]
        6| Minimum flow rate =      4000 [ml/min]
        7| Time limit       =         60 [minutes]
Data    8| Pump data period  =         1 [minutes]
Start   9| Scheduled start:   03/09/18 11:59:33
                Time now:   03/09/18 11:44:35
D| Done.
                Selection [] ?
```

*Figure 6-25: Deployment Parameters*

4. Immediately after confirming the clock, the user must define parameters for the deployment. Depending on the optional features such as the Trigger start, programming procedures may differ slightly.

## Flow Rates

<b>Pump</b>	<b>Sample Volume</b>	<b>Flow Rate</b>	<b>Min. Flow Rate</b>
<b>4L/min</b>	1 – 10000 liters	1000 – 5000 ml / min	500 ml / min
<b>8L/min</b>	1 – 20000 liters	4000 – 10000 ml / min	3000 ml / min
<b>30L/min</b>	1 – 50000 liters	120000 – 30000 ml / min	10000 ml / min

## Start options

**Scheduled start:** A scheduled start requires entering the date and time for pumping to begin. The scheduled start timer should be used to program longer delays.

**Count-down timer:** The count-down timer start begins counting when the deployment is confirmed, and begins pumping when the timer reaches zero. The count-down timer can be set in 1 minute increments from 5 minutes up to 24 hours. If the count-down delay is set to 0 hours a setting of at least 5 minutes will be required.

**Trigger start:** A trigger start time synchronizes multiple instruments. The trigger delay countdown begins when the trigger plug is disconnected and reconnected (until the trigger plug is disconnected, the system remains awake). When the trigger plug is disconnected, the firmware goes into Sleep mode. When the trigger plug is activated (plugged in), the Trigger Delay countdown begins.



Scheduling properly accounts for leap years.

## Sample Pump Data Period

While pumping a sample the WTS-LV logs pumping diagnostic data to memory at a set interval. This interval is defaulted to one minute, and can be programmed using option <8>.

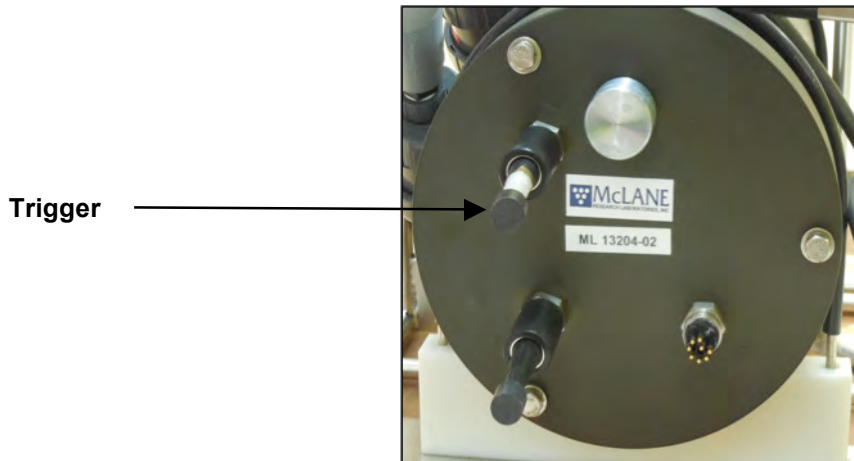
## Trigger Start Delay

To program the trigger delay, select menu option <9>. The use of the trigger start is to synchronize multiple WTS-LV samplers. Factor in the desired start time of each sampler when setting the trigger delay for each WTS-LV pump.

```
Header  1| Trigger Test, 03-09-2018
        2| s/n 12345-01
        3| CGP
Sample  4| Sample volume      =      10 [liters]
        5| Initial flow rate =      7000 [ml/min]
        6| Minimum flow rate =      4000 [ml/min]
        7| Time limit        =         3 [minutes]
Data    8| Pump data period =         1 [minutes]
Start   9| Trigger delay:      00:05:03 [HH:MM:SS]
        D| Done.
        Selection [] ? d
Trigger test:
        Disconnect and reconnect trigger plug, or press ^C to abort...
        Trigger is functioning.
Selection [] ? d
Trigger test:
        Disconnect and reconnect trigger plug, or press ^C to abort...
        Trigger is functioning.
```

**Trigger start, countdown 5 minutes, 3 seconds** ←

*Figure 6-26: Setting Trigger Countdown Delay*



*Figure 6-27: Trigger Plug*

The system will stay awake and wait for the trigger delay to be activated for deployment when the trigger is plugged into the endcap.

```
Selection [] ? d
Trigger test:
Disconnect and reconnect trigger plug, or press ^C to abort...
Trigger is functioning.

Performing 6 second low-power sleep mode test...

System status: 03/09/18 11:21:10 35.8 Vb 25°C

Caution: Deployment will overwrite the
          EEPROM data backup cache.

Proceed with the deployment [N] ? y
Trigger delay: 00:05:03 [HH:MM:SS]

Disconnect and reconnect trigger plug, or press ^C to abort...
Trigger received.

Waiting for scheduled event @ 03/09/18 11:26:23
Remove communication cable and attach dummy plug.

System is ready to deploy...
```

*Figure 6-28: Proceed with Deployment, Trigger Activated*

## Starting the Deployment

After the deployment parameters are defined, the WTS-LV system can be started.

Start a deployment:

1. Type *D* if already at the Deployment Parameters screen or select Main Menu option <5> Deploy System.
2. If the trigger start is defined, the system will prompt the user to remove and reconnect the trigger plug on the end cap.
3. The system next performs a six second a low-power sleep mode test to verify that backup power is functioning properly.
4. If data from a previous deployment exists in memory or EEPROM, a system warning will warn that data is going to be deleted before continuing with the deployment. Type *Y* to continue.
5. If using the trigger start, remove the trigger plug from the end cap and reconnect the plug. This activates the trigger countdown start delay. The system remains awake until the trigger plug is disconnected and reconnected. Do not press [CTRL]-[C] after the trigger is activated or the deployment will be stopped.
6. The system then prompts the user to remove the communications cable and connect the dummy plug onto the communications bulkhead connector.



**Waking the sampler after this point will cancel the deployment.** If the user is curious whether the system is still working DO NOT wake the device. Instead connect to the device, and press any key. The system will print the system time and “Suspended until” the start time of the next scheduled event.

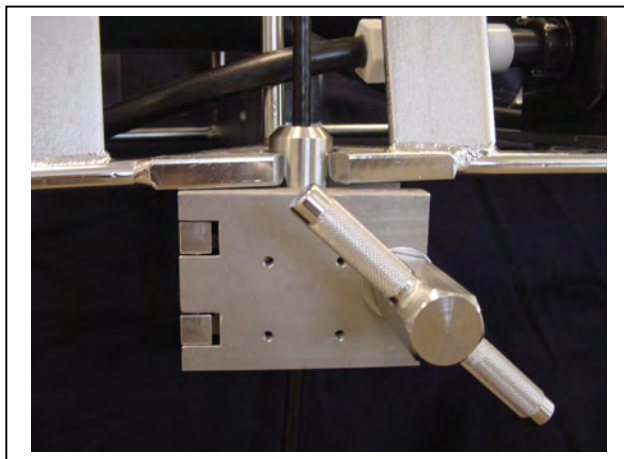
## Final steps before Deployment

Final steps for deploying the WTS-LV requires the following (in order):

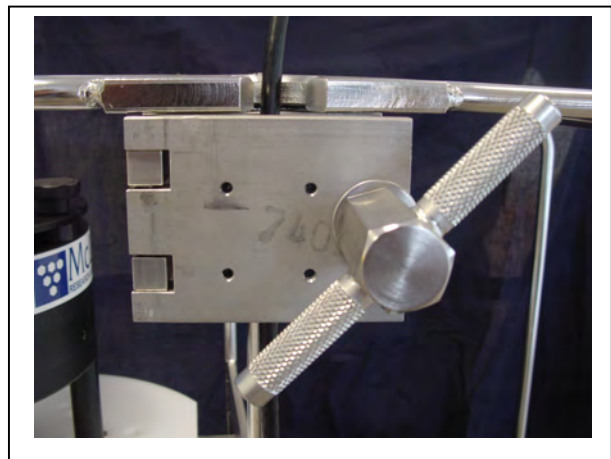
- Connect the battery and close the end cap (see chapter 4 “Getting Started” for details about the end cap and connectors).
- Connect the communications cable and confirm firmware deployment settings (see chapter 6 “Deployment Preparation” for details about programming the deployment).
- Disconnect the communications cable and attach the dummy plug.
- Attach the WTS-LV clamps to the mooring wire (see steps that follow in the next section for detailed instructions).
- Install the trigger plug just prior to putting the WTS-LV over the rail.
- Allow the instrument to flood near the surface for a few minutes before deploying to the target depth to ensure that the exhaust lines are completely wet.

### Steps for Connecting the WTS-LV to the wire

As shown below, the WTS-LV has two cable clamps that are designed for fast and easy attachment to and from oceanographic wires. The bottom clamp attaches to the wire first (supporting the full system weight) and the top clamp (which is permanently attached to the frame) is secured second.



*Figure 6-29: Bottom Clamp*



*Figure 6-30: Top Clamp*

Attach the WTS-LV to the wire by completing the following steps:

1. Secure the pin clamp around the wire and tighten the T-nut until the clamp is fastened (the pin should face pointing up, see Figure 6-29).
2. Slide the WTS-LV frame down onto the pin clamp placing the hole at the bottom of the frame onto the pin clamp.
3. Secure the top clamp to the wire confirming that the wire is taught between the top and bottom clamps (see Figure 6-30).
4. Confirm that both clamps are well tightened (a shackle can be placed around the deployment cable and connected to the WTS-LV with a short cable bridle as a safety wire).



Pumping begins whether or not the WTS-LV is on station. Reconnecting the COM cable and typing [CTRL]-[C] will terminate the deployment.



# Chapter 7

## Deployment Recovery and System Maintenance

### Recovery Procedure

After the deployment is completed, the required steps are:

- Retrieve the filter for sample analysis.
- Offload the deployment data.
- Clean WTS-LV fluid paths and plumbing.

### Removing the Filter

After a deployment is complete and the system has been recovered, the filter holder can be removed for sample analysis. To remove the standard WTS-LV filter, complete the following steps:

1. Power on the computer, plug the COM cable into the computer serial port, and then connect the COM cable to the controller housing.
2. Select <3> 'Run Pump' from the WTS-LV Main menu.
3. Select <1> 'Run pump: forward' from the Manual Operation menu.
4. To remove standing water from the filter holder run the pump at the minimum flow rate for 3-5 seconds and press [CTRL]-[C] to stop pumping when the standing water is gone.
5. Disconnect the tubing from the filter holder and unscrew the three large black screws under the filter holder plate.
6. Move the entire filter holder to a protected location.
7. Unscrew the four knurled nuts and remove the filter holder top.
8. Remove the 142 mm filter and store/secure as necessary for analysis.
9. Replace the top section of the filter holder and secure it with the knurled nuts.
10. Place the filter holder back onto its plate and install the three large black screws.
11. Reconnect the tubing to the filter holder.
12. If the WTS-LV is not being immediately redeployed, perform any necessary maintenance as described later in this chapter.

## Offloading Deployment Data

Deployment event data and pumping data is stored to volatile memory and non-volatile EEPROM during a deployment. After a system is recovered this data can be offloaded and captured to a text file for future analysis.

```
Configuration: LV-8M_TR                      CF2 V2_10 of Jan 11 2018

-----
Offload/Display Data File
-----

Fri Mar  9 12:16:37 2018

<1> Display ALL data
<2> Display event summary data
<3> Display pump data
<4> EEPROM data backup cache

<M> Main Menu

Selection  [1] ?
```

*Figure 7-1: Offload/Display Data File Menu*

Connect the communications cable to a computer and then connect the communications cable to the WTS-LV.



The computer should be on and McLaneTerm running before connecting to the WTS-LV electronics. Do not disconnect the battery (which erases the data) until checking the capture files to confirm that the data offload was successful.

### Offload menu options:

**<1> Display ALL data:** Displays all event summary and pumping data stored in volatile RAM memory. If power is removed, this data is lost.

**<2> Display event summary data:** Displays only event summary data.

**<3> Display pump data:** Displays only the pumping data recorded and the pump data interval programmed while setting up the deployment.

**<4> EEPROM data backup cache:** Displays EEPROM event data summary. While the data is limited, it will remain in memory after power is cycled.

To offload deployment data:

1. Establish communication with the WTS-LV and start a capture file named "WTS-LV\_OFFLOAD\_[DATE & TIME].txt".
2. Select Main Menu option <6> to offload data.
3. Select Offload Menu option <1> to display all data. After all the data has been printed to the screen press any key to return to the offload menu.
4. Select Offload Menu option <4> to display the backup deployment data summary to the screen. Press any key to return to the offload menu.
5. Stop logging to file.
6. Select Offload menu option <M> to return to the main menu, and put the device to sleep.

```
Configuration: LV-8M_TR                               CF2 V2_10 of Jan 11 2018
-----
Offload/Display Data File
-----
Fri Mar 9 12:16:27 2018

<1> Display ALL data
<2> Display event summary data
<3> Display pump data
<4> EEPROM data backup cache

<M> Main Menu

Selection [1] ? 1

Start the capture file now.

Then, press any key to start the transfer. The data
file will remain in memory and is not erased by this
offload procedure.

Software version: LV-2_10.c
Compiled: Jan 11 2018 16:21:24
Electronics S/N: ML12345-01

Data start: 03/09/18 11:57:02
Data stop: 03/09/18 12:13:54
```

Figure 7-2: Offload/Display Data File – Display All (1 of 2)

HEADER

Bench Test, 03-09-2018

s/n 14519-01

CGP

Sample volume: 120 liters  
Initial flow rate: 8000 ml/min  
Minimum flow rate: 4000 ml/min  
Time limit: 31 minutes  
Pump data period: 1 minutes  
Scheduled start: 03/09/18 11:57:01

DEPLOYMENT DATA

Event start: 03/09/18 11:57:02 35.7 Vb 23 °C  
120.00 L delivered in 1011 seconds : Volume reached  
Event end: 03/09/18 12:13:54 35.8 Vb 26 °C

Normal shutdown.

PUMPING DATA

Sample interval = 1 [minutes]

[L/min]	[liters]	[Vbat]	[Av. mA]	[High mA]
7.99	6.94	35.6	499	517
8.03	14.08	35.6	505	511
8.03	21.21	35.6	501	510
7.99	28.35	35.6	499	507
8.03	35.48	35.6	498	505
8.03	42.62	35.6	497	506
7.99	49.75	35.6	496	505
7.99	56.89	35.6	495	503
7.99	64.02	35.6	494	503
8.03	71.15	35.6	494	501
8.03	78.29	35.6	494	503
8.03	85.42	35.6	493	502
7.99	92.56	35.6	492	501
8.03	99.69	35.6	491	498
7.99	106.82	35.6	490	498
7.99	113.95	35.6	489	498

Lowest battery voltage measured while under load: 35.6

End of instrument data file.

Terminate file logging operation now and

Press any key to continue.

Figure 7-3: Offload/Display Data File – Display All (2 of 2)

## Option <4> EEPROM Data Backup Cache

Option 4 accesses a back-up copy of critical data written to non-volatile memory during deployment. In an unlikely system malfunction, EEPROM provides limited data recovery. Make backup copies of the capture file.

```
08/11/16 10:54:56 Suspended until 08/11/16 10:59:55 ... Awake

<08/11/16 10:59:57>

Event starting . . .

  2510 h  110 I_Hz   27 A_Hz   0.1 L   4.9 L/min   1 sec  35.7 V  301 mA
  2607 h  126 I_Hz   59 A_Hz   0.1 L   5.6 L/min   2 sec  35.7 V  317 mA
. . .

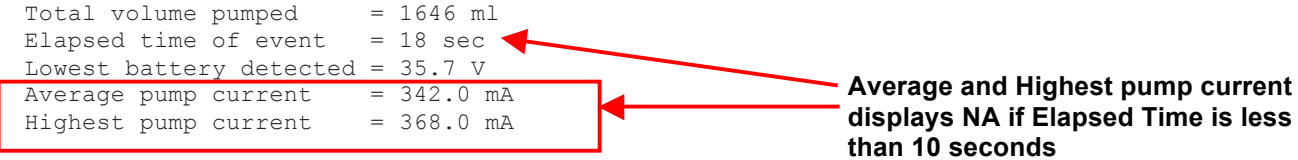
  2850 h  159 I_Hz  158 A_Hz   1.5 L   7.0 L/min  16 sec  35.7 V  359 mA
  2849 h  159 I_Hz  158 A_Hz   1.6 L   7.0 L/min  17 sec  35.7 V  366 mA

Stopped by user

Total volume pumped      = 1646 ml
Elapsed time of event    = 18 sec
Lowest battery detected  = 35.7 V
Average pump current     = 342.0 mA
Highest pump current     = 368.0 mA

<08/11/16 11:00:15>

Event finished . . .
Normal shutdown now in effect.
```



**Average and Highest pump current displays NA if Elapsed Time is less than 10 seconds**

Figure 7-4: EEPROM Data Backup Cache

## System Maintenance

Allowing the buildup of biofouling and salt is detrimental to system performance and will shorten sampler life. Flushing the WTS-LV is very important. Perform the following system checks and maintenance procedures after every deployment.

### Flushing the WTS-LV Pump Head

Option <2> from the Manual Operations menu provides a way to flush the pump head interior with fresh water. Flushing the pump head after every deployment can prevent salt crystal formation. To flush the pump head, complete the following steps:

1. Establish communication with the WTS-LV.
2. After removing the filters from the filter holder (including the port 0 flush filter), reassemble and reinstall the filter holder.
3. Place the free end of the tubing in a reservoir of fresh, clean water. Optionally, a mild detergent solution can be used for a first flush followed by a clean water flush.
4. Connect the plastic tubing (provided in the toolkit) to the pump exhaust port.
5. Remove the filter holder.
6. Select <2> Run pump: reverse from the Manual Operation menu.
7. Reverse pump five liters of fresh water to clear the pump head of salt water.
8. Watch the water container, and make sure it does not run dry.



If a cleaning solution is used to flush the system, make sure to perform another flush with water to rinse the cleaning solution from the system.

## Cleaning and Inspecting the Filter Holder

Before and after deployment, thoroughly clean the filter holder with a non-abrasive cleaner. For cleaning, the filter holder must be removed from the frame and disassembled. Do not grease the filter holder o-rings or the sample could be contaminated. The filter holder uses Viton Fluoropolymer o-rings which do not require lubrication. However, you should clean the threads and o-rings with alcohol and a lint-free wipe. Inspect the O-rings visually and feel them for wear.

## Rinsing the System

It is very important to clean and rinse the entire system after a deployment with fresh water. Storing a dirty system until the next deployment can lead to serious problems that void the warranty and prevent the WTS-LV from functioning correctly.

## Inspecting the O-Rings

See “O-Rings Maintenance” in the next section for details about o-ring inspection. O-rings should be cleaned with alcohol and lubricated with a thin coating of o-ring grease as necessary.

## Storage

The shipping crate is a reusable international freight container that is ISPM-15 compliant for international transport.



To prevent instrument damage during transport or storage, avoid excessive vibration and extreme temperatures for prolonged periods of time.

Before storing the WTS-LV for more than one month:

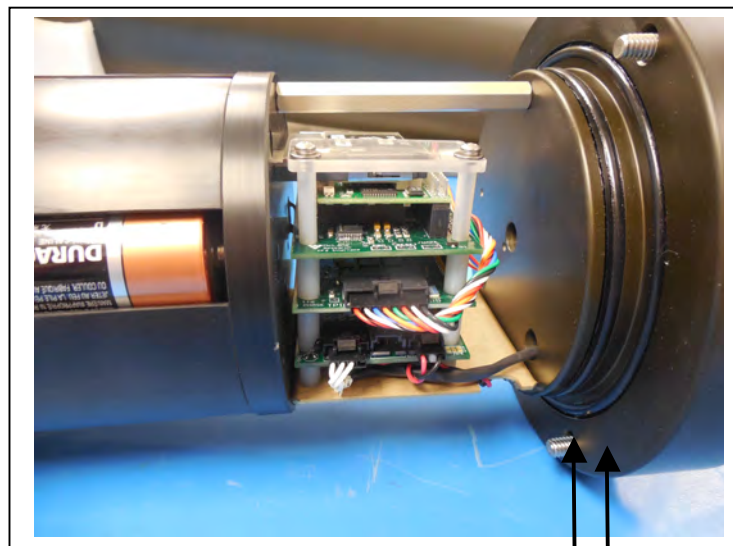
- Offload all data from memory.
- Rinse all instrument components with fresh water.
- Disassemble and rinse the filter holder.
- Always disconnect and remove batteries. For user replaceable “D” cell alkaline batteries, dispose of the batteries. If using an older system with a battery pack, cover the connector with insulation tape and store the battery in a refrigerator.
- Clean and grease controller end cap o-rings.
- Reassemble the main battery holder and insert the electronics package back into the controller housing.
- Replace all bolts and apply a small amount of anti-seize to the threads.



## O-Ring Maintenance

Both ends of the WTS-LV controller housing have a set of o-rings in the end cap. Each set includes three o-rings. O-rings must be installed properly and kept in place at all times:

- Face O-ring (2-246 70 durometer, BUNA-N)
- Radial O-ring (2-242, 70 durometer, BUNA-N)
- Backup ring: (8-242, 90 durometer, BUNA-N)



**Radial O-Ring**      **Face O-Ring**

*Figure 7-1: Controller Housing Top End Cap with O-Ring Seals*

Inspect o-rings for signs of wear and the presence of any foreign material (which can cause leaks). Look for small cracks and feel for grit, sand, or hair. O-rings should be cleaned with alcohol and lubricated with a thin coating of o-ring grease as necessary.

## Cleaning and Inspecting the Controller Housing

Before every deployment, inspect, and if necessary, replace the zinc anodes attached to the controller housing end caps. When installing new zinc anodes, use 316 stainless steel hardware and include the o-ring.



Keep hard objects such as tools or shackles away from the anodized controller housing. Scratches from these objects will localize galvanic action and can cause deep crevices or pitting.

# Appendix A

## WTS-LV Models

This Appendix explains the non-standard WTS-LV sampler models.

Contents	
Section	Sensor
A.1	Dual Filter Model
A.2	Upright Model
A.3	Bore Hole Model

## Notes

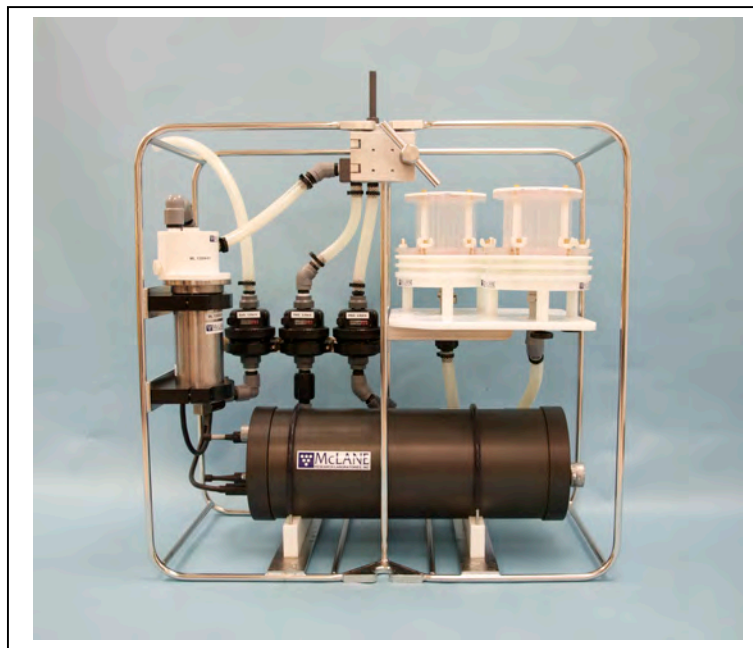
## Section A.1

### WTS-LV Dual Filter Model

The dual filter WTS-LV model (WTS-LVDF) features two vertical intake 142 mm filter holders that allow for simultaneous, independent sampling within the same water mass. The LVDF model is designed for applications that require sampling of very large water volumes in order to capture sufficient amounts of trace elements, suspended metals or other particulate matter. The vertical intake filter holder follows a modular design and functions as an optional replacement for the standard radial intake filter holder in traditional WTS-LV and Upright LV systems.

The vertical intake filter holder incorporates increased internal baffling in order to mitigate losses of large particles during handling and recovery of the instrument. The ability to utilize two different filter porosities during a single deployment allows for greater sampling flexibility and may increase overall volume capacity when compared to single filter designs. Other features include:

- A72-1000 battery pack (30,000 mAh), which provides three times the battery capacity of the standard WTS-LV.
- Trigger start to time synchronize and simultaneously deploy multiple instruments.
- Independently metered flow circuits plus metered “total output” at exhaust.



*Figure A.1-1: WTS-LV Dual Filter Model*

# Section A.1.1 Specifications

## WTS-LV Dual Filter Model Dimensions

The WTS-LV Dual Filter instrument dimensions are as follows:

Length (body)	79 cm (31.25 in)
Width	38 cm (15 in)
Height	74.9 cm (29.5 in)

## Filter Porosity

The WTS-LVDF is calibrated to perform optionally with membrane filters ranging from 0.22  $\mu\text{M}$  to 3.00  $\mu\text{M}$  or greater porosity. A cross section of the filter holder is shown next.

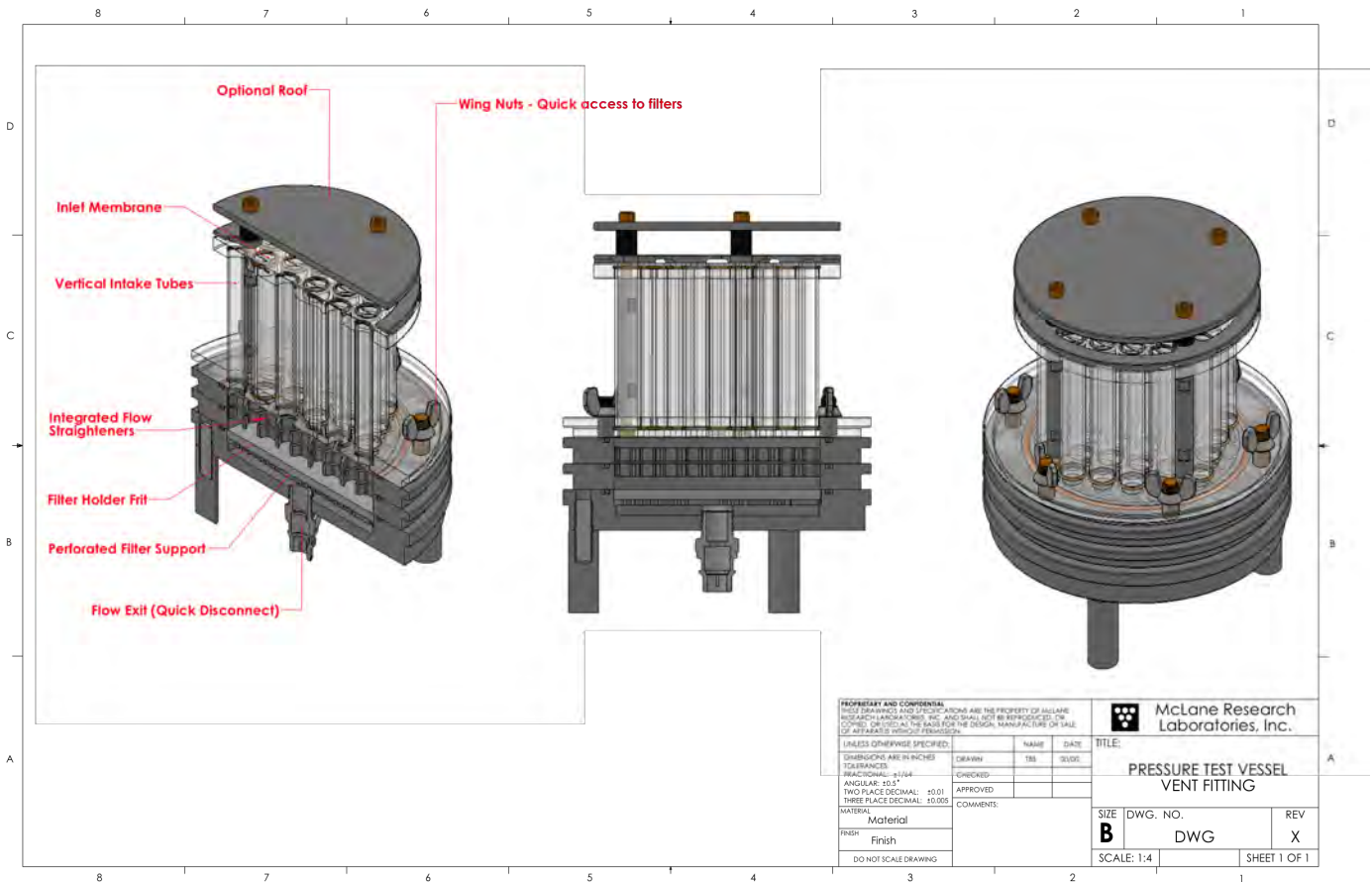


Figure A.1.1-1: WTS-LV-DF Filter Holder Cross Section

The diagram shown next illustrates the intake flow path.

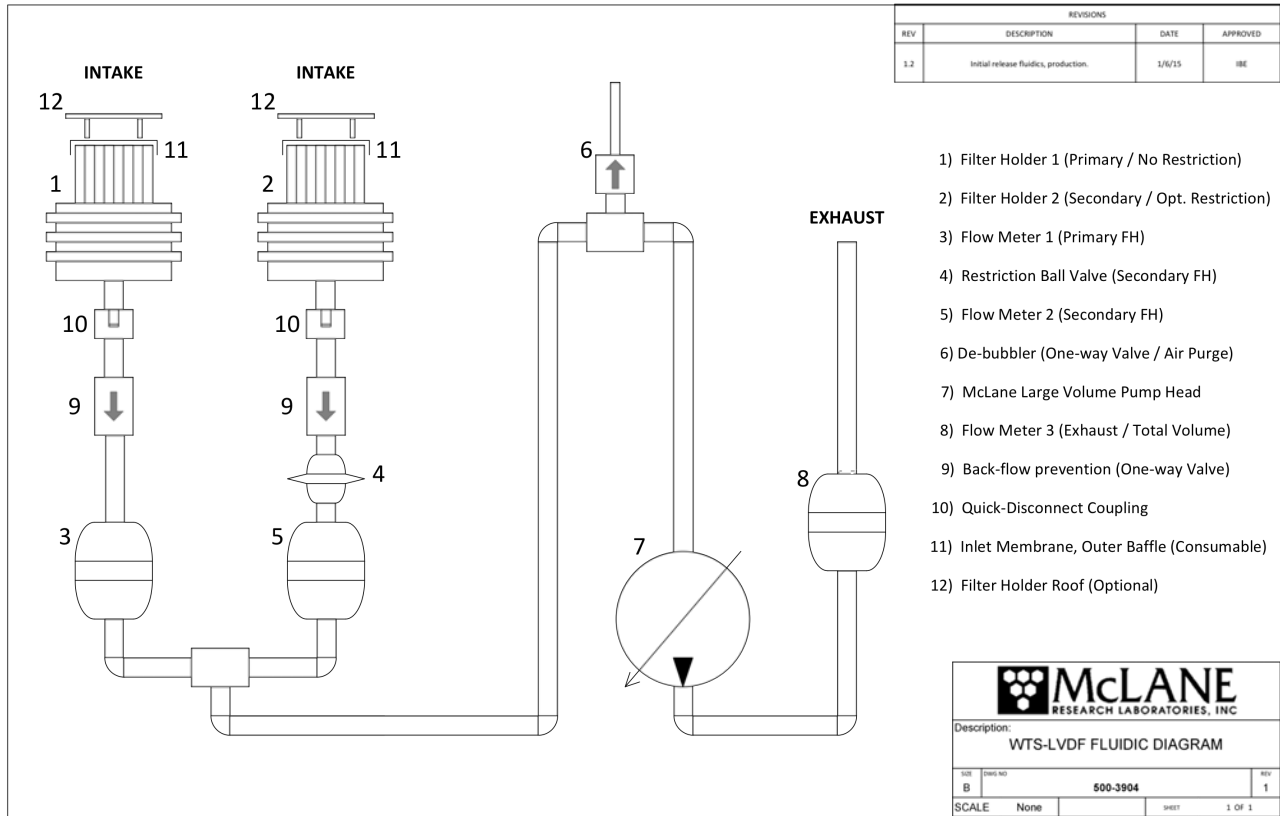
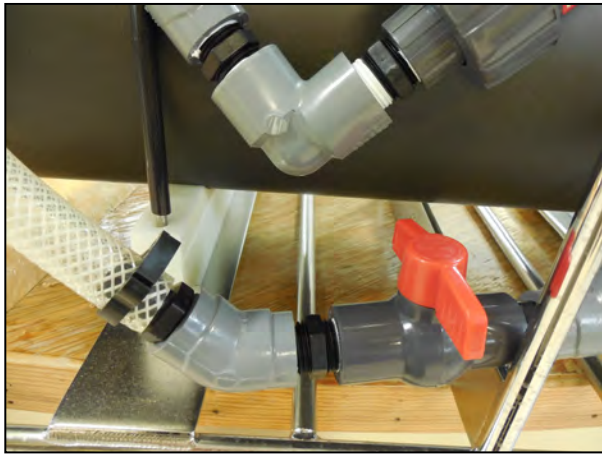


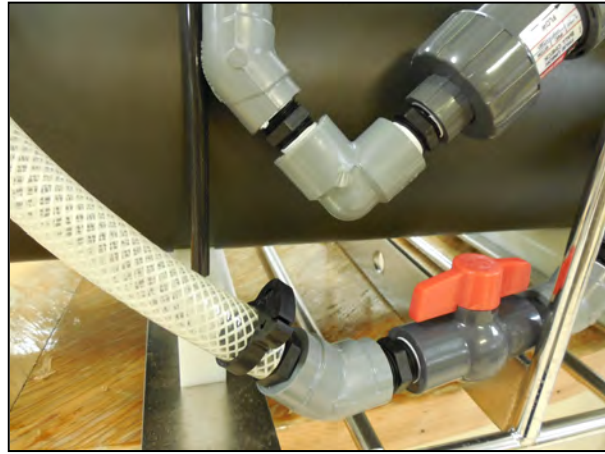
Figure A.1.1-2: WTSLV-DF Fluidic Diagram

## Section A.1.2 WTS-LVDF Operations

The WTS-LVDF vertical intake filter holder is interchangeable with the traditional radial intake on standard WTS-LV systems. To operate the WTS-LVDF as a single filter sampler, turn the red flow valve counterclockwise. Figures A.1.2-1 and A.1.2-2 show the flow valve positions for single and dual filter sampling.



*Figure A.1.2-1: Valve Closed*



*Figure A.1.2-2: Valve Open*



## Removing Filter Holders

The WTS-LVDF ships with filter holders installed. To remove either filter holder, complete the following steps:

1. Remove each of the three thumb screws at the bottom of the filter holder plate.
2. Press to release the quick disconnect fitting from below the filter holder.



*Figure A.1.2-3: Remove Nuts and Release Quick Disconnect*

3. Gently lift the filter holder from the filter holder plate and remove filter holder unit from connector.



*Figure A.1.2-4: Lifting Filter Holder off of Plate*

## Installing Filter Holders

To install either filter holder, complete the following steps:

1. Place the filter holder over the filter holder plate and push the connector onto the quick disconnect.



*Figure A.1.2-5: Securing Filter Holder to Quick Disconnect*

2. Secure the three thumb screws through the filter holder plate up into the filter holder legs.
3. Confirm that the red flow valve is correctly set for either single or dual filtering.

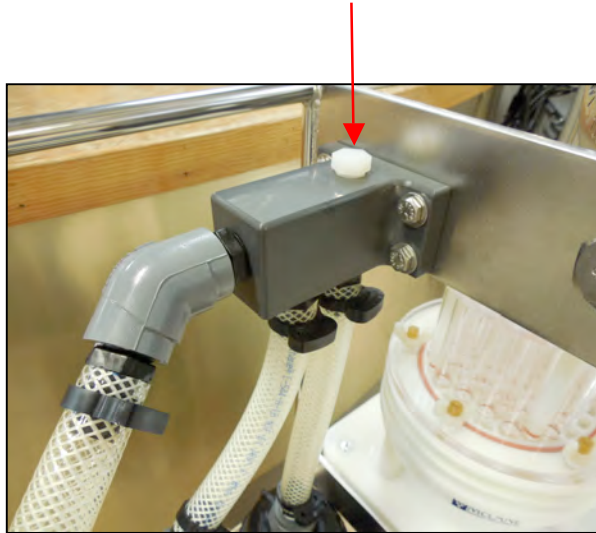


*Figure A.1.2-6: Flow Valve Positioned for Dual Filtering*

## Section A.1.3 WTS-LVDF Deployment Preparation

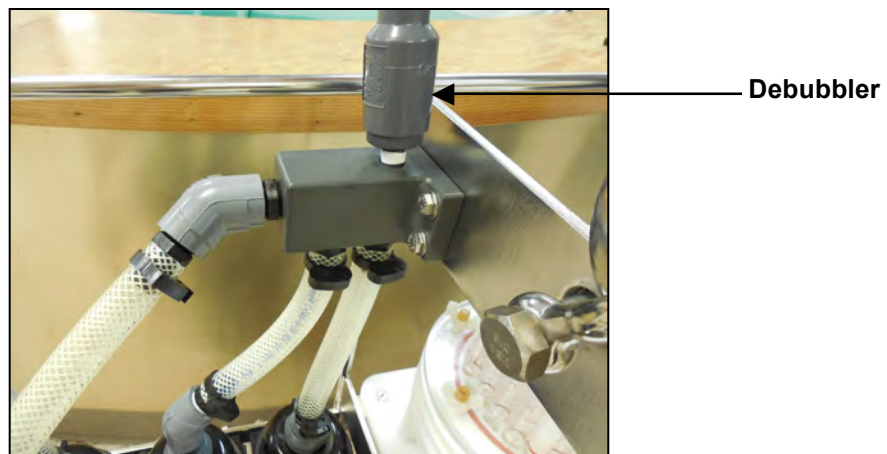
### Installing the Optional Debubbler

The WTS-LVDF ships with an optional debubbler. The debubbler must be installed prior to use. The WTS-LVDF must be deployed with plug at the top of the manifold in place if the debubbler is not installed. Spare plugs are included in the toolkit.



*Figure A.1.3-1: Debubbler Plug*

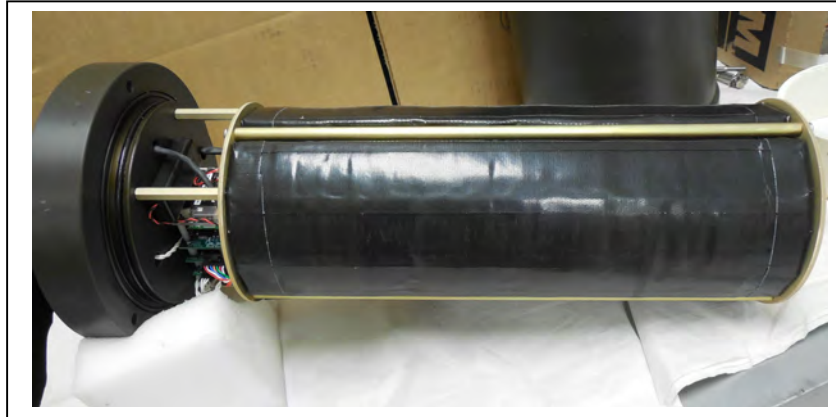
Remove the plug from the top of the manifold. Screw the threaded end of the debubbler into the manifold until tight.



*Figure A.1.3-2: Screw Debubbler into Manifold*

## Connecting the Battery

Connecting and disconnecting the battery to the electronics powers the WTS-LVDF on and off. The firmware starts automatically when either the main or backup batteries are connected.



*Figure A.1.3-3: WTS-LVDF Controller with A72-1000 Battery Pack*

To power on the WTS-LVDF and connect to a computer, complete the following steps:

1. Place the WTS-LVDF in a dry area.
2. Boot the operator PC and start the communications software.
3. Open the WTS-LVDF controller housing.



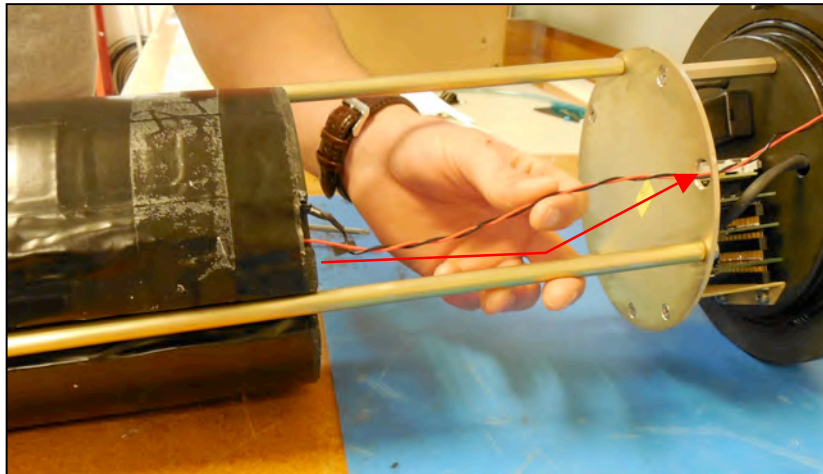
Follow standard electrostatic discharge (ESD) precautions when handling the electronics and place the WTS-LVDF in a dry area.

- Using a screwdriver, loosen the screws and remove the bottom plate.



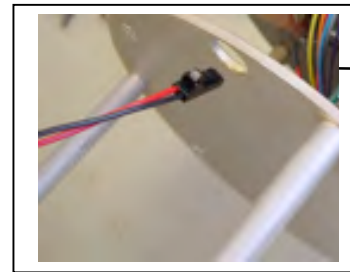
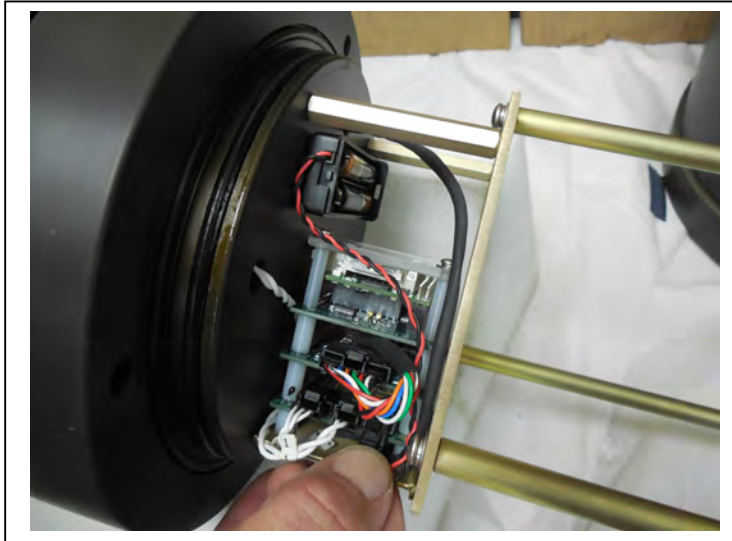
*Figure A.1.3-4: Removing Battery Housing End Plate*

- Align the battery to insert the connector through the hole in the Top Plate.



*Figure A.1.3-5: Align Battery to Fit Connector Through Hole in Top Plate*

- When installing the A72-1000 battery pack, align the hole in the battery frame with the wires at the top of the battery. Feed the connector wires through the battery feed through hole in the battery holder frame. (Figure A.1.3-6).



**Battery Feed-Through**

*Figure A.1.3-6: Correctly Feeding Battery Connection Wires and Connecting Battery*

- Connect the main battery to the connector on the electronics stack.
- Close the controller housing.
- Remove the dummy plug from the communications connector.
- Attach the communication cable assembly (supplied in the Toolkit) first to the PC serial port and then to the main battery bulkhead connector on the controller housing.
- Before disconnecting power, press [CTRL]-[C] to return to the Main Menu and select Sleep
- Continue with deployment steps as explained in the 'User Interface' chapter of this User Manual.

## Priming the WTSLV-DF

Priming the WTSLV-DF is a best practices procedure recommended by McLane. To prime the sampler, complete the following steps

1. Locate the priming fixture from the toolkit. Connect the fixture to Inlet 2.
2. Connect the sampler to a computer and run the Pump Forward firmware option to fill lines with water.

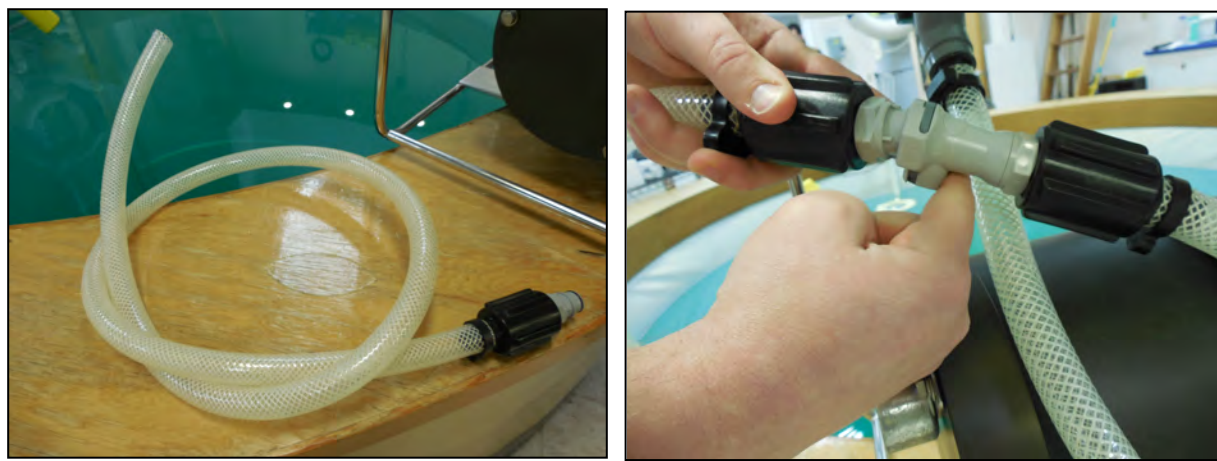


Figure A.1.3-7: Priming Tubing and Quick Disconnect

```
Configuration: LV-08M_TR                CF2 V2_06 of Mar 10 2014
```

```
Manual Operation
```

```
Fri Apr 18 14:11:54 2014
```

```
<1> Run pump forward (10 liters @ 7 L/min)
<2> Run pump reverse (10 liters @ 7 L/min)
<3> Run pump programmable
```

```
<M> Main Menu
```

```
Selection [M] ? 1
```

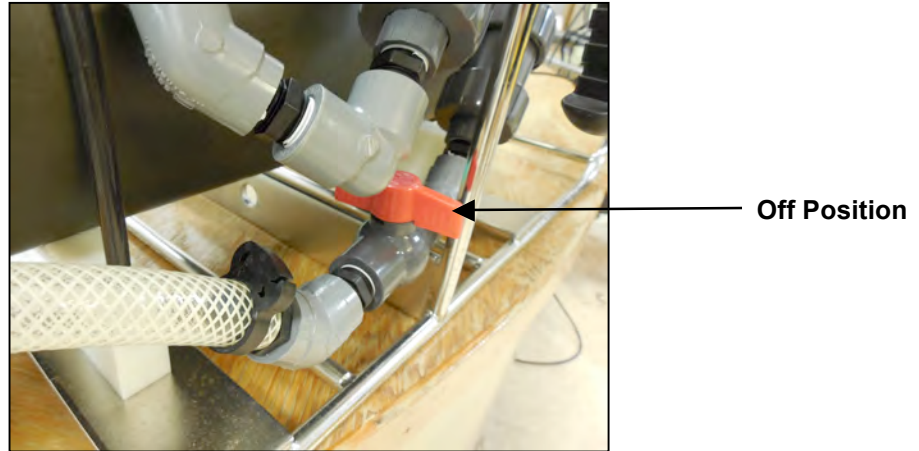
```
2399 h 209 I_Hz  52 A_Hz   0.1 L   9.2 L/min   1 secs
2303 h 207 I_Hz 104 A_Hz   0.3 L   9.1 L/min   2 secs
2224 h 198 I_Hz 153 A_Hz   0.4 L   8.7 L/min   3 secs
. . .
2012 h 159 I_Hz 158 A_Hz   9.7 L   7.0 L/min   98 secs
2013 h 158 I_Hz 158 A_Hz   9.8 L   7.0 L/min   99 secs
2012 h 159 I_Hz 158 A_Hz   9.9 L   7.0 L/min  100 secs
```

```
Volume reached
```

```
Total volume pumped      = 9993 ml
Elapsed time of event      = 101 sec
Lowest battery detected   = 36.0 V
Press any key to return to pump menu.
```

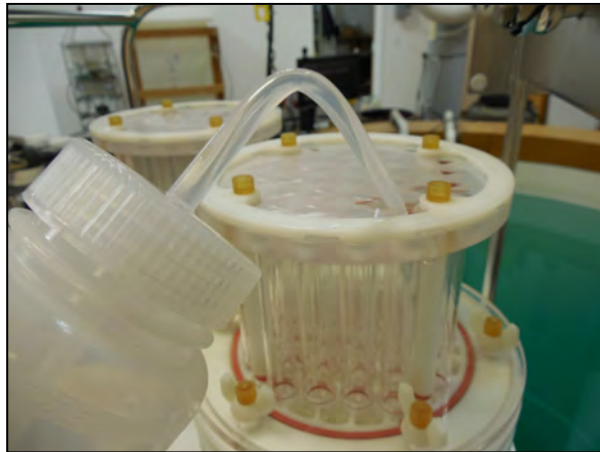
Figure A.1.3-8: Run Pump Forward

3. Turn the red flow valve for the side being primed to the ‘off’ position, then attach priming tube to Inlet 1.



*Figure A.1.3-9: Setting the Flow Valve*

4. Run the Pump Forward firmware option.
5. Attach filter holders. Using a squirt bottle, fill the top of the filter holder with clean deionized water.



*Figure A.1.3-10: Filling Filter Holder Top with Water*



## Reading and Recording Flow Meters

The WTS-LVDF has three flow meters. Each filter holder has a flow meter and the third flow meter is for the exhaust. Recording the mechanical flow meters before and after deployment is a recommended best practice that provides an accurate reading of volume pumped. This reading is a true measurement compared to the firmware pumped volume reading, which can vary greatly based on deployment conditions and filter types.



*Figure A.1.3-11: Mechanical Flow Meters*

## Section A.2

### WTS-LV Upright Model

The WTS-LV upright model includes the same features and user interface as the standard WTS-LV. This Appendix explains the following options on the upright model that differ from the standard WTS-LV:

- Larger controller housing to accommodate the A72-1000 battery pack (30,000 mAh), which provides three times the battery capacity of the standard WTS-LV.
- Trigger start to time synchronize and simultaneously deploy multiple instruments.



*Figure A.2-1: WTS-LV Upright Model*

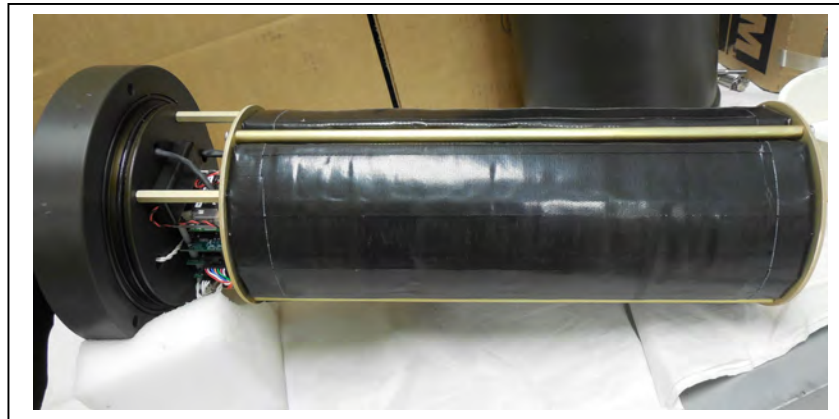
## WTS-LV Upright Model Dimensions

The WTS-LV upright model instrument dimensions are as follows:

Length (body)	91 cm (36 in)
Width	61 cm (24 in)
Height	33 cm (13 in)

## **Connecting the Battery**

Connecting and disconnecting the battery to the electronics powers the WTS-LVUP on and off. The firmware starts automatically when either the main or backup batteries are connected.



*Figure A.2-2: WTS-LVUP Controller with A72-1000 Battery Pack*

To power on the WTS-LVUP and connect to a PC, complete the following steps:

1. Place the WTS-LVUP in a dry area.
2. Boot the operator PC and start the communications software.
3. Open the WTS-LVUP controller housing.



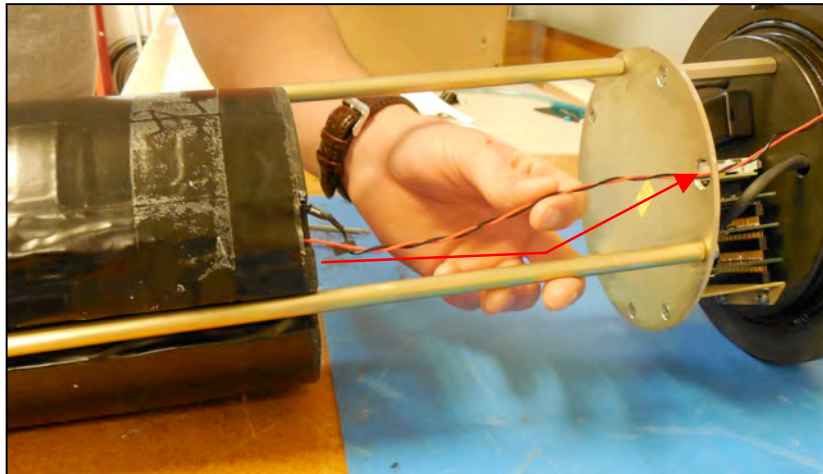
Follow standard electrostatic discharge (ESD) precautions when handling the electronics and place the WTS-LVUP in a dry area.

- Using a screwdriver, loosen the screws and remove the bottom plate.



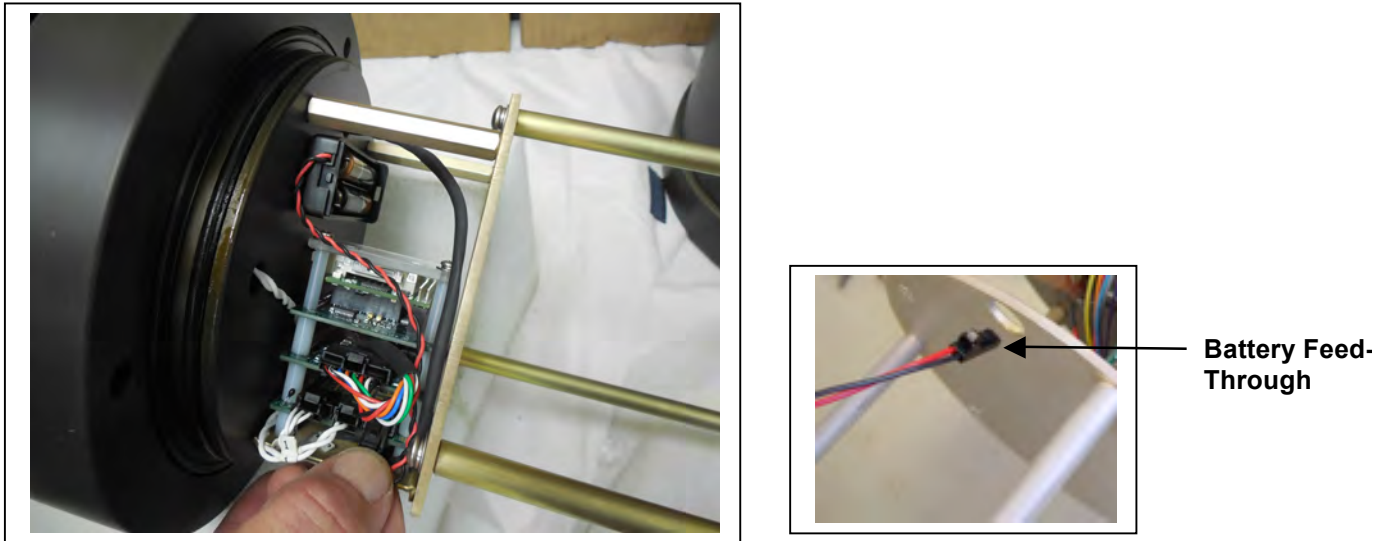
*Figure A.2-3: Removing Battery Housing End Plate*

- Align the battery to insert the connector through the hole in the Top Plate.



*Figure A.2-4: Align Battery to Fit Connector Through Hole in Top Plate*

- When installing the A72-1000 battery pack, align the hole in the battery frame with the wires at the top of the battery. Feed the connector wires through the battery feed through hole in the battery holder frame. (Figure A.2-5).



*Figure A.2-5: Correctly Feeding Battery Connection Wires and Connecting Battery*

- Connect the main battery to the connector on the electronics stack.
- Close the controller housing.
- Remove the dummy plug from the communications connector.
- Attach the communication cable assembly (supplied in the toolkit) first to the PC serial port and then to the main battery bulkhead connector on the controller housing.
- Before disconnecting power, press [CTRL]-[C] to return to the Main Menu and select Sleep
- Continue with deployment steps as explained in the ‘User Interface’ chapter of this User Manual.

### Trigger Start

For details on the Trigger Start see Chapter 2 “System Description” and Chapter 6 “Deployment Preparation”, in this User Manual.

## Deploy

```
Selection [] ? D

System status:

   Date      Time      Battery      Temp Port
03/17/15 13:18:27 30.8 Vb  18.0°C 00 (home)

Caution: Deployment will overwrite the EEPROM data backup cache.

Performing 6 second Backup Battery test...

!!! CANNOT CONTINUE - CHECK BACKUP BATTERY !!!
```

*Figure A.2-6: System Status*

The steps that follow explain how to complete the deployment.

1. Select *D* to proceed with the deployment when the sample parameters are complete.
2. One line of system status information displays followed by a message reminder to offload data written to the EEPROM backup during a previous deployment. Disregard the message if the data has already been recovered.
3. The data offload reminder and battery check will be followed by and a prompt to proceed with or terminate the deployment (a final chance to check the settings prior to deployment).
4. The firmware performs a consistency check. If the main battery voltage is too low to support the deployment, warnings will display.

5. Once the system is ready to deploy, remove the communications cable, replace the dummy connector, and connect to the wire. The system will remain in the Suspend mode until the scheduled time of the pumping event. At that time the system will automatically wake up and begin sampling.

```
CAUTION: Deployment will ERASE all EEPROM data backup entries.  
  
Proceed with the deployment [N] ? y  
  
Trigger delay: 00:30:00 [HH:MM:SS]  
  
Disconnect and reconnect trigger plug, or press ^C to abort...  
  
Trigger received.  
  
Waiting for scheduled event @ 04/06/15 12:29:08  
  
Remove communication cable and attach dummy plug.  
  
System is ready to deploy...  
  
04/06/15 11:59:08 Suspended until 04/06/15 12:29:08 ...
```

*Figure A.2-7: Deploy System – Trigger Installed*



Pumping begins whether or not the WTS-LV is on station. Reconnecting the COM cable and typing [CTRL]-[C] will terminate the deployment.

## Section A.3

### WTS-LV Bore Hole Model

The Bore-Hole WTS-LV (Figure A.3-1) is designed to fit through a narrow opening such as a 30cm bore-hole and collect a single suspended particulate sample *in situ* onto a 142mm membrane filter.



*Figure A.3-1: Bore-Hole WTS-LV*



The Bore-Hole WTS-LV is identical to the standard WTS-LV, with a re-arrangement of the components. The physical dimensions and component arrangement are illustrated in Figure A.3-2:

Height: 160cm (63in)

Diameter: 26cm (10.36in)

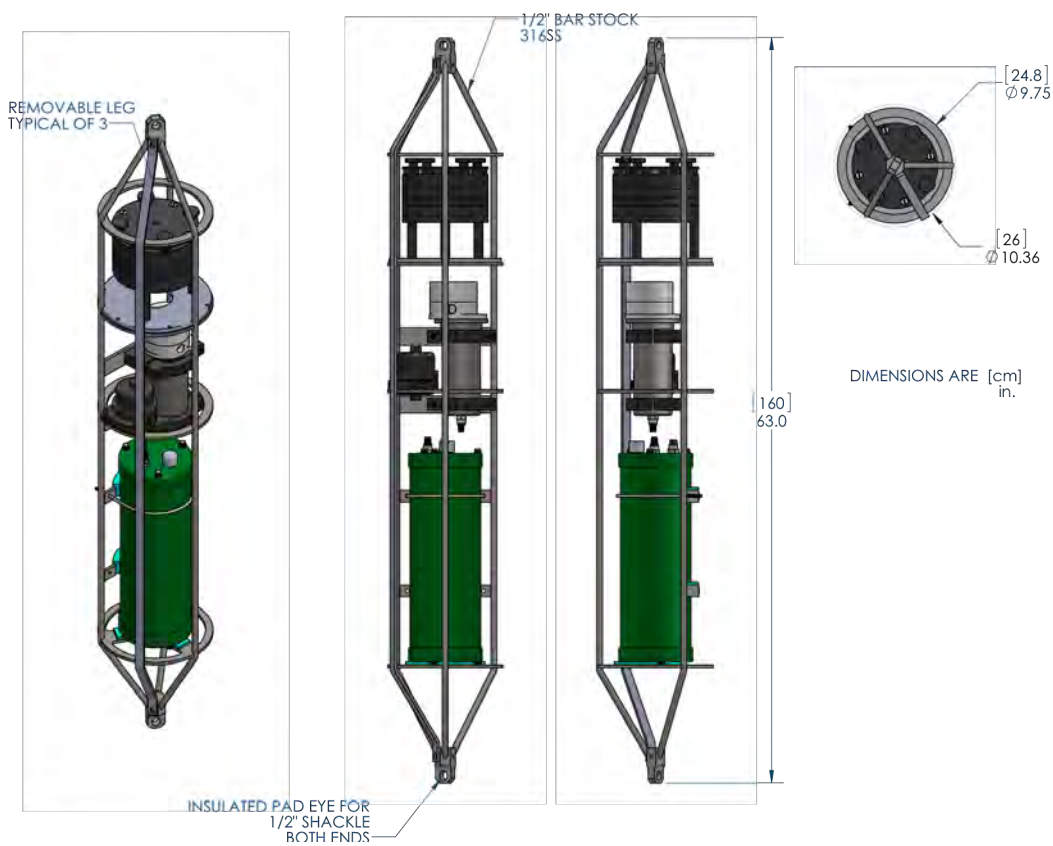
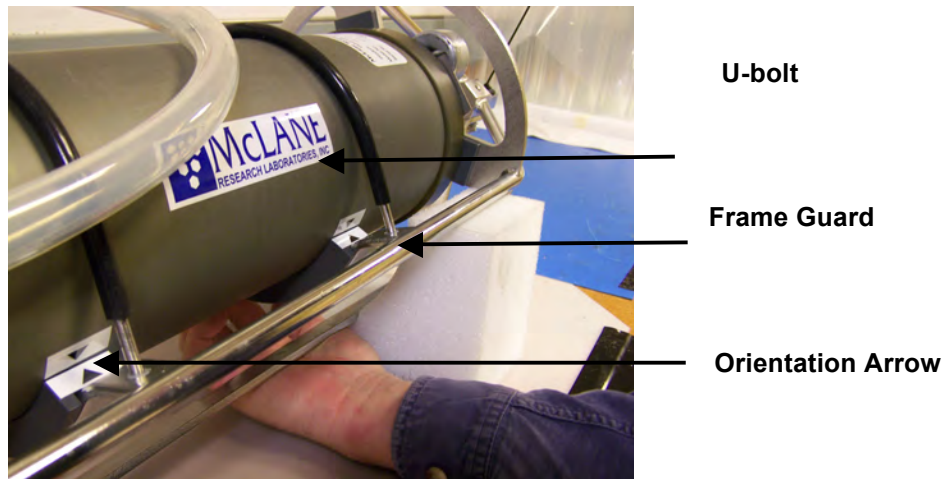


Figure A.3-2: Bore-Hole WTS-LV Schematic

## Installing the Batteries

The Bore-Hole WTS-LV uses the drop-in battery pack (same as the standard WTS-LV), which contains 24 user replaceable “D” cell alkaline batteries and has 10,000 mAh of battery capacity. To install the batteries, one of the three frame guards that protect the controller housing and the two u-bolts that secure the controller housing must be removed and the controller housing lifted out of the frame.



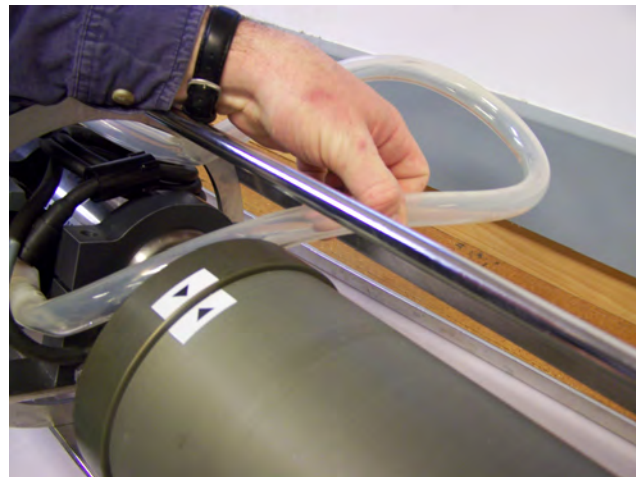
*Figure A.3-3: WTS-LV Frame Guards, U-Bolts and Orientation Arrows*

A 7/16” Box Wrench and an Adjustable Wrench are included in the toolkit as shown in Figure A-3.4 to remove and reinstall the frame guard and u-bolts.

When removing the controller housing, the white exhaust tubing can be moved out of the way or disconnected at the inlet to the flow meter as shown in Figure A.3-5. To install batteries in the controller housing, complete the steps shown next:

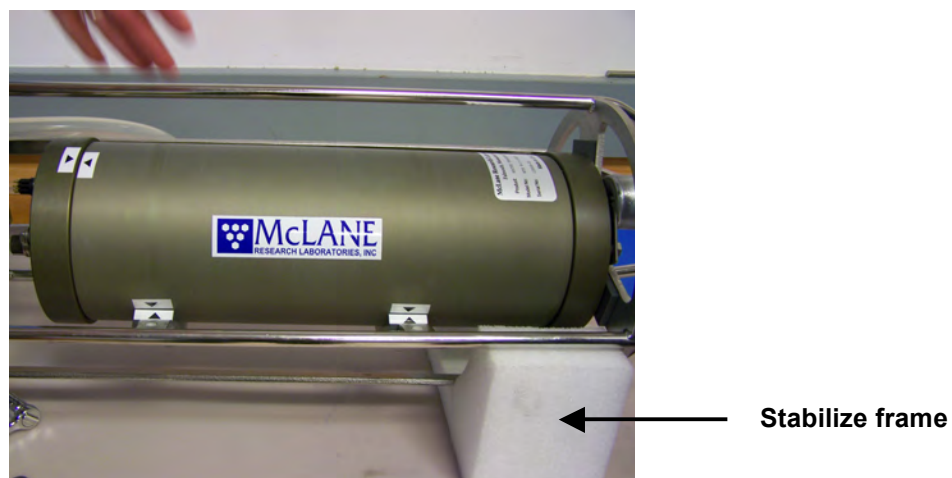


*Figure A.3-4: 7/16" Box Wrench, Adjustable Wrench*



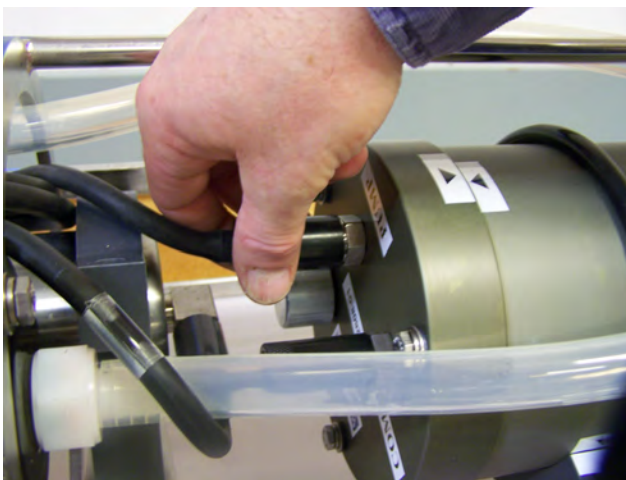
*Figure A.3-5: Moving Exhaust Tubing*

1. Position the WTS-LV on a flat surface and stable support so that it does not roll (Figure A.3-6). Foam cradles from the shipping crate work well for this purpose.



*Figure A.3-6: Place on a Stable Surface*

2. Remove the connector from the controller housing (Figure A.3-6).
3. Using the adjustable wrench, loosen the connecting bolt on one of the frame guards (Figure A.3-7)

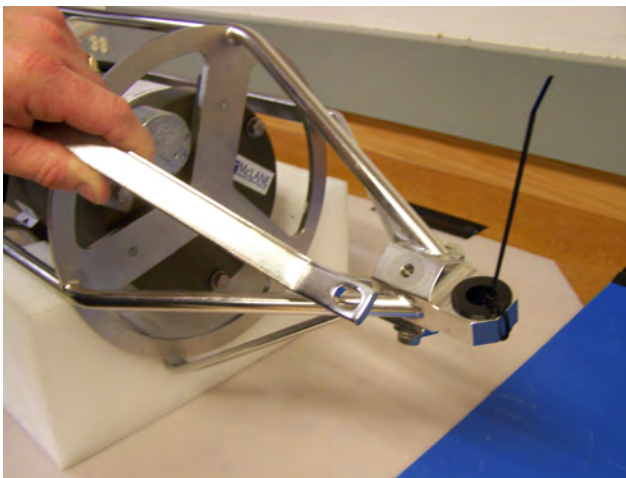


*Figure A.3-7: Removing Connector*



*Figure A.3-8: Loosening Frame Guard*

4. Slide the frame guard away from the controller housing (Figure A.3-9).
5. Using the box wrench, loosen the bolts at the bottom of the u-bolts (Figure A.3-9).



*Figure A.3-9: Removing Leg Bolt*



*Figure A.3-10: Loosening U-Bolt Clamp*

6. Using the box wrench, loosen the bolts at the bottom of the u-bolts and remove the u-bolts (Figure A.3-11).
7. Gently lift the controller housing away from the frame (Figure A.3-12).

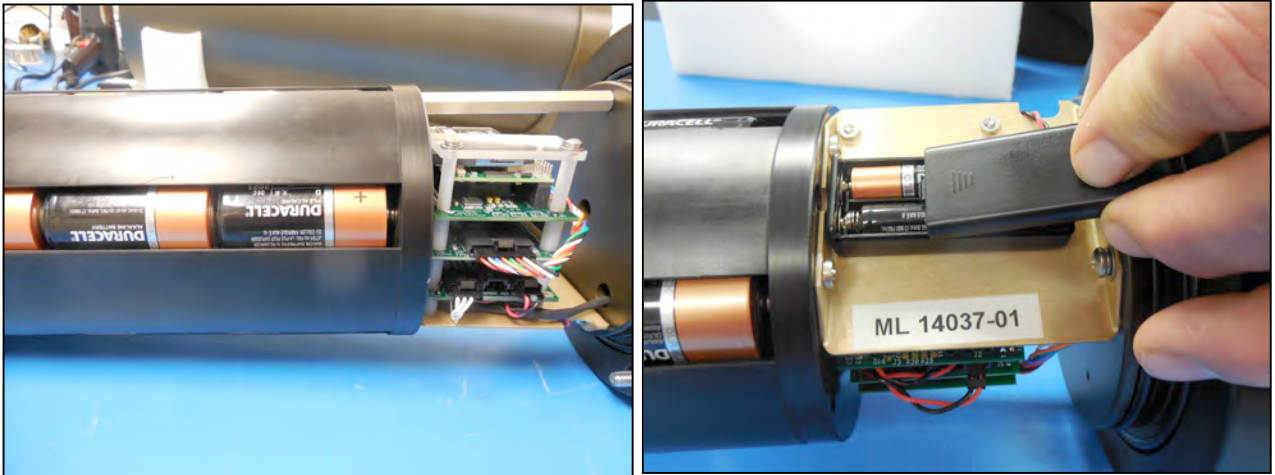


*Figure A.3-11: Removing U-Bolt*



*Figure A.3-12: Removing Controller Housing*

8. See Chapter 2 “System Description” in this User's Manual for the steps to install batteries.
9. Plug in the battery connector to power the electronics before closing the controller housing.



*Figure A.3-13: Main and Backup Batteries*

10. Connect the main battery to the 2-pin connector on the middle board of the electronics stack.
11. Close the controller housing.

12. Return the controller housing to the frame and reattach the bulkhead connector.
13. Position the controller housing with the alignment arrows as shown in Figure A.3-15.



Correctly aligning the end cap with the orientation arrows is important to ensure proper alignment of the top end cap bulkhead connectors.



*Figure A.3-14: Returning Controller to Frame    Figure A.3-15: Aligning Arrows, Reattaching Connector*

# Appendix B

## Optional Filter Holders

Filters for the WTS-LV are supplied by the user. Available filter holder styles include the standard, vertical intake, 3-tier, cartridge, zooplankton and 293mm filters. The chart in Figure B-1 shows the filter holder options and compatibility with different WTS-LV models. This Appendix describes the 3-tier, and cartridge filter holders. Appendix ‘WTS-LV Dual Filter Model’ has information about the Vertical Intake filter holder option.

	Standard Radial	Vertical Intake	3-Tier	Cartridge	Zooplankton	293mm
<b>Sampler Fit</b>	WTS-LV, WTSLV-DF, WTS-LV-UP, WTSLV-BH	WTS-LV, WTSLV-DF, WTS-LV-UP, WTSLV-BH	WTS-LV, WTSLV-DF, WTS-LV-UP, WTSLV-BH	WTS-LV	WTS-LV, WTS-LV-UP	WTS-LV (special frame)
<b>Description</b>	Radial intake has large horizontal intake openings at the top provide low resistance path to the filter	Vertical intake minimizes particle wash out	Large horizontal intake with additional pre-filter (mesh or glass)	Cartridge housing for standard 2.5 x 10 inch double open ended (DOE) cartridges	Valved intake	Same as standard radial filter holder with larger diameter for more filter surface area
<b>Filter Size &amp; Specs</b>	142mm mesh, GFF or membrane	142mm mesh, GFF or membrane	142mm mesh, GFF or membrane	10in DOE Cartridge filter	203mm mesh 60µm or greater	293mm mesh or GFF
<b>Flow Rates</b> (Dependent on filter load and pore size)	2-8 liters/min (based on pump head size)	2-8 liters/min (based on pump head size)	2-8 liters/min (based on pump head size)	Variable with choice of cartridge	Up to 30 liters/min depends on mesh size	2-8 liters per minute
<b>Material</b>	Black Acetal	HDPE/Acrylic	Black Acetal	Styrene Acrylonitrile (SAN) & Polypropylene	HDPE	Black Acetal

WTS-LV and WTS-LV-BH powered by 24 drop-in "D" cell alkaline batteries (10,000 mAh). WTSLV-UP and WTSLV-DF powered by A72-1000 battery pack (30,000 mAh) (3x the battery capacity of the drop-in "D" batteries). Trigger is standard on all WTS-LV models.

17.G.11

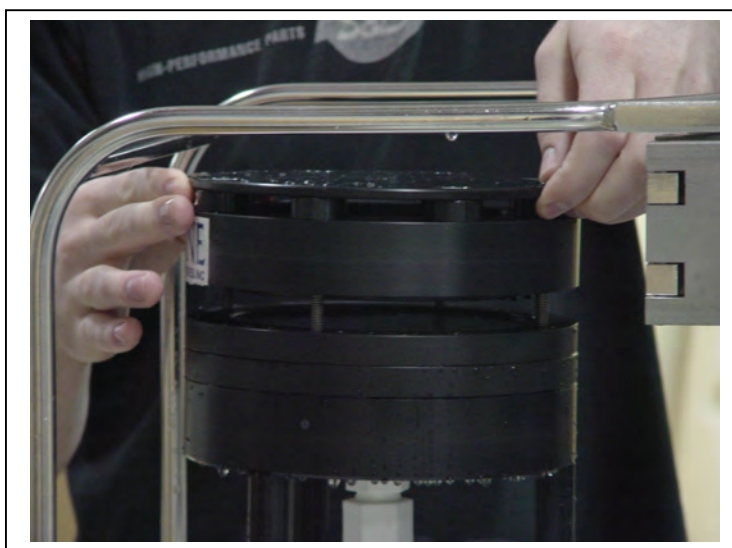
McLane Research Laboratories, Inc. • [www.mclanelabs.com](http://www.mclanelabs.com) • 121 Bernard Saint Jean Drive, East Falmouth, Massachusetts 02536 USA  
Tel: +1 508.495.4000 • Fax: +1 508.495.3333 • Skype: Mclane\_research

Figure B-1: Filter Holder Specifications Chart

## WTS-LV with Optional 3-Tier Filter Holders

The WTS-LV modular filter design permits several filters to be stacked in series and used simultaneously. Each filter tier has a filter support frit and supports an independent filter with intermediate spacing for sample accumulation. Multiple filter layers can be used for size fractionation or other specialized programs where *in situ* sample separation is appropriate.

Chapter 6 of this User Manual contains steps for priming the standard WTS-LV filter holder. Follow this procedure for priming the 3-tier filter holder.



*Figure B-2: WTS-LV 3-Tier Filter Holder*

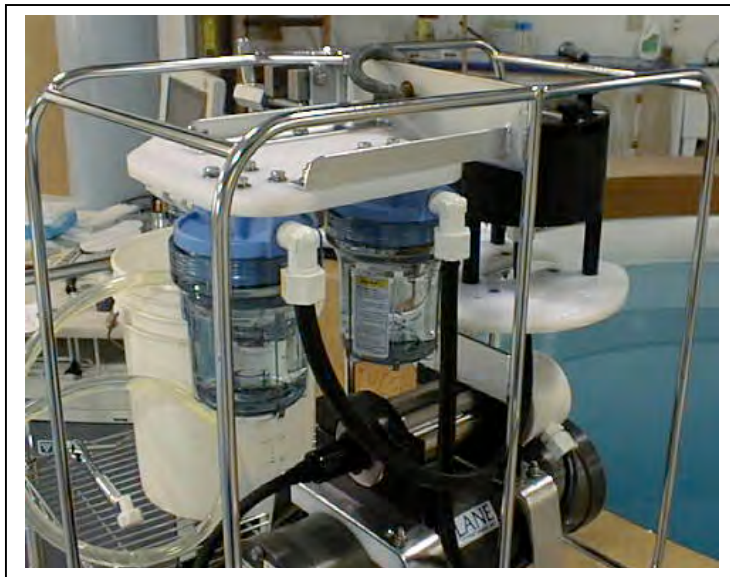


## WTS-LV with Optional Cartridge Filter Holder

If optional cartridge filter holders are used, priming is completed using reverse pumping (priming is filling the tubing between the filter holder and the pump with water before installing the filter, to displace any air pockets).



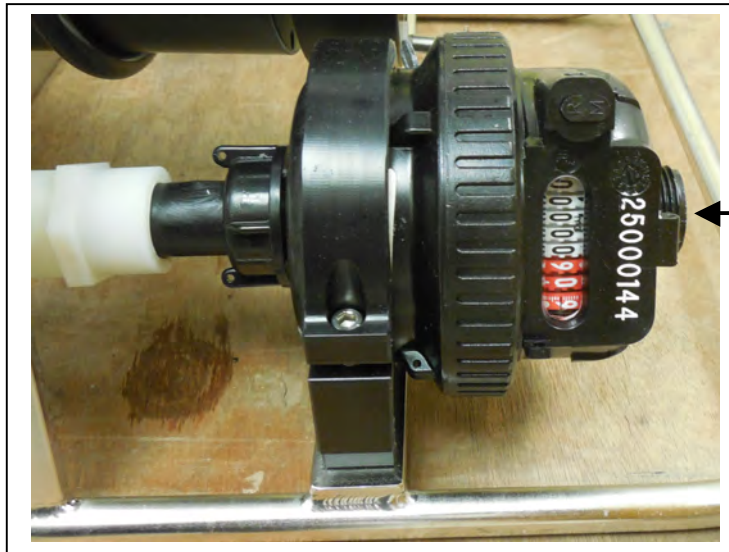
If water can be pumped through the cartridge filters in reverse, install them before the priming process, otherwise install them after the priming is completed. When installing filters after priming, completely refill the cartridge holders before reinstalling on the system.



*Figure B-3: WTS-LV with Cartridge Filter Holders*

To prime the pump when the cartridge filter holder is in use, complete the following steps:

1. Without removing the filter holder from the frame, unscrew the four knurled nuts located on the top of the assembly and remove the filter holder top and any prefilters.
2. Attach the priming tubing with the quick disconnect (included in the toolkit) to the pump exhaust port located at the end of the flow meter (see Figure B-4).



*Figure B-4: Exhaust Port*

3. Once the priming tubing is connected to the pump exhaust, boot the PC, plug the COM cable into the PC serial port and then connect the COM cable to the controller housing.
4. Connect the battery if necessary (if this is the first use of the WTS-LV, the battery will be inside the controller housing but not connected). Steps for connecting the battery are in chapter 3 of this User Manual.
5. Close and seal the controller housing.
6. Using a beaker, pour water into the open end of the priming tube until water drips from one of the Cartridge Holders.
7. Place the free end of the priming tubing into a (minimum) 5 gallon bucket or large reservoir containing several liters of distilled/neutral water. Keep the hose submerged during priming so that air bubbles are not introduced into the system.
8. To assist the water flow, set the reservoir with the intake tube at or above the level of the filter housings.
9. From the Main Menu of the WTS-LV firmware, select <3>, Run Pump.
10. Select <2> run pump: programmable.
11. When prompted, set the volume to several liters, the flow rate to 5000 (the minimum value), the minimum flow rate to 4000 (the minimum value), and the time limit to several minutes.
12. At the prompt, type 'R' Reverse pumping.

13. The pump will begin drawing water into the system from the bucket (each of the cartridge holders will fill up consecutively). Once the cartridge holders are all full, water will enter the filter holder below the lowest frit.



This process will occur in approximately 20 seconds or less so watch carefully.

14. Once the water penetrates the frit and begins filling the void above the frit, press [CTRL]-[C] to stop pumping.

## Notes

# Appendix C

## Pump Head Sizing and Filter Types

### Available WTS-LV Pump Heads

*\* LV08 is standard on the WTS-LV*

The tables shown next provide a list of available pump heads and recommendations based on compatible filter type and flow rate.

Pump Size	LV04	*LV08	LV30
Flow Rate Range (L/min)	1–5	4–10	12–30

### Filter Types and Recommended Pump Heads

Filter Type	Pore Size (micron)	Max Flow Rate (L/min)	Recommended Pump Heads		
			LV04	LV08	LV30
Polycarbonate and Polyester Membrane (Nucleopore <sup>®</sup> , Millipore <sup>®</sup> )	0.2	3	●		
Polycarbonate and Polyester Membrane (Nucleopore <sup>®</sup> , Millipore <sup>®</sup> )	0.4	4	●		
Polycarbonate and Polyester Membrane (Nucleopore <sup>®</sup> , Millipore <sup>®</sup> )	0.8	8	●	●	
Polycarbonate and Polyester Membrane (Nucleopore <sup>®</sup> , Millipore <sup>®</sup> )	1.0	10	●	●	
Glass Fiber (GF/F <sup>®</sup> , QMA <sup>®</sup> )	0.8	8	●	●	
	1.7	10	●	●	
	5.0	20	●	●	●
Mesh (Nytex <sup>®</sup> )	60.0	30	●	●	●

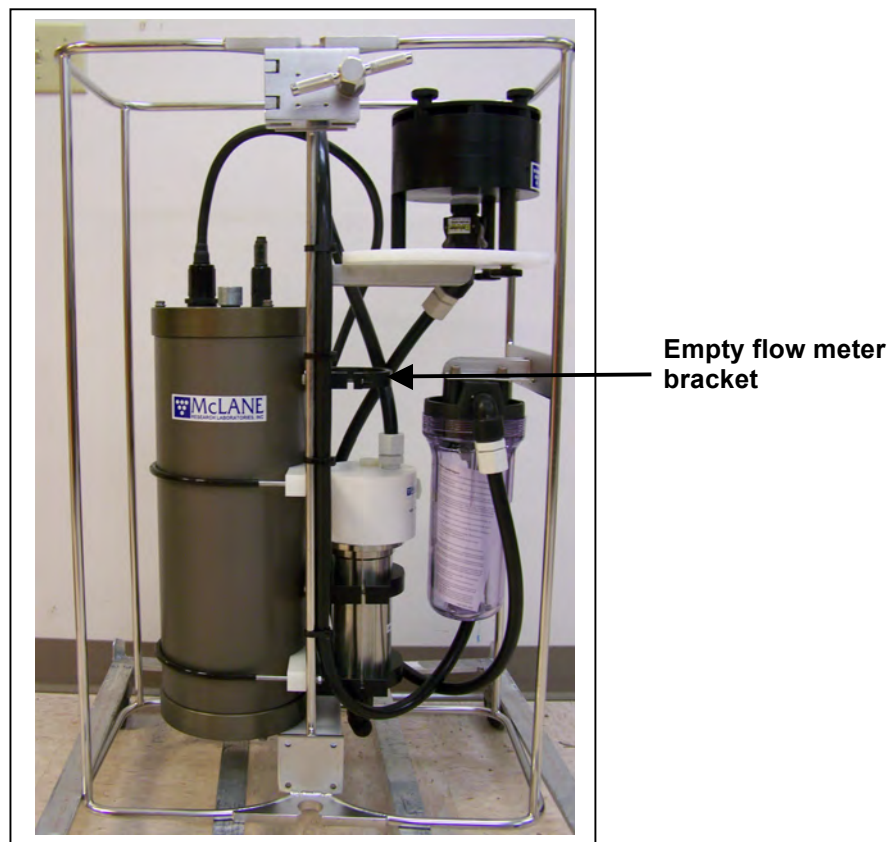
## Notes

## Appendix D

### Using the 30L/Min Pump

The 30L/min pump head is an optional feature of the Upright WTS-LV model (WTS-LVUP). The maximum flow rate of 30L/min can be reached with a 100  $\mu$ m mesh filter, no frit, no cartridge housing and no flow meter installed. Installing a frit, cartridge housing and/or flow meter produces lower maximum flow rates.

As shown in Figure D-1, the WTS-LVUP with 30L/min pump is shipped with no flow meter installed (the flow meter is included in the crate). Installing the flow meter creates back pressure on the pump exhaust which slows the maximum flow rate. A 16L/min flow rate is the maximum that is reached with the flow meter installed. Pump testing results shown on the next page explain how maximum flow rate is affected by the flow meter, cartridge housing, and frits.



*Figure D-1: WTS-LV Upright with 30L/min Pump Head*

The table below shows flow rate results testing the 30L/min pump head with different options. A 2000 mA motor current was used for this testing. There was no filter in the cartridge housing to maximize the flow rate. As shown, adding a cartridge filter holder or flow meter further reduces the maximum flow rate.

Filter	Frit	Cartridge Housing	Flowmeter	Maximum Flow Rate (L/min)
100 $\mu$ m Mesh	None	None	None	30
3 $\mu$ m	Standard	None	None	25
3 $\mu$ m	Standard	10" DOE (double open ended plumbing only - no filter installed)	None	23
3 $\mu$ m	Standard	10" DOE (double open ended plumbing only - no filter installed)	V100	16



The WTS-LV requires a filter with a pore size of 3  $\mu$ m or greater. Pumping through a 3  $\mu$ m filter with the 30L/min pump head, no cartridge housing and no flow meter produces a maximum flow rate of 25L/min. When the 30L/min pump head is installed, the WTS-LVUP firmware initial pumping flow rate can be set from 15000 to 25000 ml/min (15L/ - 25L /min). Using the flow meter reduces the maximum flow rate to 16L/min.



## Deployment Programming Settings

The screens that follow show deployment settings when the 30L/min pump is installed.

```
Configuration: LV-30G_TR                      CF2 V2_07 of Jan 15 2015

      McLane Research Laboratories, Inc.
      Large Volume Sampler
      ML12345-02

      -----
      Main Menu
      -----
      Tue Jun 16 10:52:47 2015

<1> Set Time           <5> Deploy System
<2> Diagnostics       <6> Offload Data
<3> Manual Operation  <7> Contacting McLane
<4> Sleep             <C> Configure

Selection [ ] ? c Password: ***

-----
Configuration: LV-30G_TR                      CF2 V2_07 of Jan 15 2015

      -----
      Configuration Menu
      -----
      Tue Jun 16 10:52:53 2015

<A> Pressure Sensor   [No]
<B> Pump              [Gearhead 30 L/Min.]
<C> Rechargeable Battery [No]
<D> Trigger          [Enabled]

<X> Save & Exit      <^C> Cancel & Exit

Selection [ ] ? x

Configuration successfully stored
```

Figure D-2: WTS-LV Configuration Settings

The WTS-LV is expected to stop pumping on minimum flow rate due to accumulation of the sample on the filter. The sampler will also stop pumping if the sample volume or time limit is reached or the battery drops below 18 V.

```
-----
Configuration: LV-30G_TR                CF2 V2_07 of Jan 15 2015

      McLane Research Laboratories, Inc.
      Large Volume Sampler
      ML12345-02

-----
                        Main Menu
-----
                        Tue Jun 16 10:58:01 2015

      <1> Set Time           <5> Deploy System
      <2> Diagnostics       <6> Offload Data
      <3> Manual Operation  <7> Contacting McLane
      <4> Sleep             <C> Configure

      Selection [ ] ? 5

Clock reads 06/16/15 10:58:06.  Change [N] ? y

Format is mm/dd/[yyyy or yy] hh:mm:ss

Enter correct time [06/16/2015 10:58:09] ? 06/16/2015 10:58:15

Clock reads 06/16/15 10:58:15.  Change [N] ?

-----

Header 1|
        2|
        3|

Sample 4| Sample volume   =      100 [liters]
        5| Initial flow rate =    20000 [ml/min]
        6| Minimum flow rate =    10000 [ml/min]
        7| Time limit      =         9 [minutes]

Data   8| Pump data period =         1 [minutes]

Start  9| Countdown timer:  01:00:00 [HH:MM:SS]

        D| Done.  Continue pre-deployment set-up.

        Selection [ ] ? 1

> Test, 6-16-2015
```

← Initial Flow Rate 15000 – 25000 mL/min

Figure D-3: WTS-LV Deployment Settings

## Battery Endurance Example Calculation

Battery life for a planned WTS-LV upright sampler deployment can be estimated using the instrument current consumption values provided here. These values apply to the CF2 microcontroller. A 30L/min pump operated at 25L/min is used for the example. In addition to pumping time, many other deployment conditions can affect the battery duration. Use this example for estimation only.

- The pre-deployment pumping time assumes initial setup steps and does not include bench testing or running diagnostics.
- Pumping assumes an unrestricted flow.

### Battery Estimate – A72-1000 Battery

The WTS-LV Upright model uses an A72-1000 battery with a 30,000 mAh capacity.

<b>Pre-deployment</b>	
Controller (1 hour)	1 h x 15 mA = 15 mAh
Pumping (0.2 hour)	0.2 x 2000 mA = 400 mAh
	<b>Subtotal = 415 mAh</b>
<b>Deployment</b>	
Controller (6 hours)	6 h x 15 mA = 90 mAh
Pumping (6 hours)	6 h x 2000 mA = 12,000mAh
	<b>Subtotal = 12,090 mAh</b>
<b>Recovery</b>	
Controller (1 hour)	1 h x 15 mA = 15 mAh
	<b>Subtotal = 15 mAh</b>
<b>Total Power Consumption</b>	<b>Total = 12,520 mAh</b>

In this example deployment, the estimated battery drain totals 12,520 mAh. This is less than the 30,000 mAh capacity of the A72-1000 battery.

## Notes

# Appendix E

## Training Videos

There is a priming and pre-deployment training video available for the WTS-LV. This video is included on the media that ships with a new sampler and can also be downloaded from the McLane website at:

<http://www.mclanelabs.com/product-type/samplers/wts-lv-video>

A description of each video and content is provided below for reference.

<b>Video</b>	<b>Content</b>
WTS-LV Battery Video	Replacing the Standard WTS-LV battery holder.
WTS-LV (Large Volume Pump) Battery Unit Change	Changing the battery unit on a Standard WTS-LV.
WTS-LV (Large Volume Pump) Deployment Preparation	Replacing the battery on the Standard WTS-LV, changing a filter, removing the filter holder unit, connecting to a computer.

## Notes